



**AUSTRALIAN NATIONAL KENNEL COUNCIL**

**FLYBALL RULES**

**Rules for the conduct of Flyball Competitions**

**(Effective from 21 September 2009)**

**Amended  
October 2008  
September 2009**

**Rules reproduced under the Agreement between the Australian National Kennel Council and  
the Australian Flyball Association Inc.**

## TABLE OF CONTENTS

### **CHAPTER 1 – CONDUCTING A SANCTIONED COMPETITION** **1**

- Section 1.1 – Requirements
- Section 1.2 – Points
- Section 1.3 – Format and Schedule
- Section 1.4 – Seed Times and Break Out Penalties
- Section 1.5 – Meaningless Heats

### **CHAPTER 2 – RULES FOR COMPETITION**

- Section 2.1 – Code of Ethics
- Section 2.2 – Misconduct
- Section 2.3 – Amateur Competition
- Section 2.4 – Changes Teams
- Section 2.5 – Protest
- Section 2.6 – Record Times

### **CHAPTER 3 – EQUIPMENT**

- Section 3.1 – Flyball Boxes
- Section 3.2 – Balls
- Section 3.3 – Jumps

### **CHAPTER 4 – RING SET UP**

- Section 4.1 – Footing
- Section 4.2 – Barriers
- Section 4.3 – Ring Layout

### **CHAPTER 5 – TEAMS AND TIME SHEETS**

### **CHAPTER 6 – MEASURING AND HEIGHT CARDS**

- Section 6.1 – Measuring
- Section 6.2 – Height Cards

### **CHAPTER 7 – REPORTING FOR RACES**

## **CHAPTER 8 – PRACTICE RUNS**

## **CHAPTER 9 – RULES OF RACING**

Section 9.1 – Jump Heights

Section 9.2 – The Race

Section 9.3 – Aggressive Dogs

Section 9.4 – Lamé Dogs, Bitches in Season,  
Dogs Recovering from Surgery, Leg Wrapping

## **CHAPTER 10 – JUDGE’S AND STEWARDS**

Section 10.1 – Judges

Section 10.2 – Judges Guidelines

Section 10.3 – Judges and Stewards Duties

## **CHAPTER 11 – FLYBALL TITLES**

Section 11.1 – Titles – Title Points System

## **CHAPTER 12 – RULE CHANGES**

## **CHAPTER 13 – INVESTIGATIONS**

**Appendix A – Guidelines for Dogs Behaviour**

**Appendix B – Forms**

**Appendix C – Round Robin Competition Format**

**Appendix D – Elimination Competition Format**

**Appendix E – Judges Training Guidelines**

### Section 1.1 - Requirements

- (a) The affiliate club must submit an application to the Controlling Body stating the date, time and place of the competition; the name, address and telephone number of the organiser; any entry fee; whether the entries are limited; the closing date; the name of the Judge(s); the basis for deciding divisional tied results and any prizes and any special conditions.

Applications for unlimited entries are to be submitted at least sixty (60) days prior to the closing date. Applications for limited entries are to be submitted at least one hundred and twenty (120) days prior to the closing date. The application cannot be approved if another Controlling Body sanctioned competition is held on the same day in accordance with the following categories:

- (i) Within 100 kilometres if a local competition.
  - (ii) Within the state if a state competition.
  - (iii) Within the nation if a national competition.
- (b) All seeding and placing of teams in divisions is to be approved by the Controlling Body.
- (i) If it is necessary to run any division of less than 3 teams, it is recommended that this division be combined with an adjacent division. Division placements and breakout times for each individual division still apply, however ANKC competition points are awarded for all heats in the combined division.
  - (ii) The Controlling Body shall receive proposed seeding and competition formats from the Competition organiser no later than 7 days before the competition for review and approval.
- (c) The affiliate club must get written approval from the Controlling Body for any and all special or unusual requests.
- (d) All teams registered with the ANKC are to be notified via their Canine website and Journal of the date, time and place of the competition and the name and telephone number of the contact person prior to the closing date.
- (e) The affiliate club may not limit entries to less than four. In cases of limited entries, the affiliate club must accept entries by the date received. All the entries may be from the same club (i.e. Front Runners A team, Front Runners B team, Front Runners C team, Front Runners D team etc.). However, multiple entries of the same club are to be treated as one entry until after the closing date. Any remaining openings are to be filled by the second entry for those teams that enter more than one team, followed by the third entry for those teams that enter more than two teams and so on until the entries are filled. Clubs are required to indicate the priority of selection for multiple team entries.
- (f) ANKC recognizes two classes of competition:  
Regular and Non-Regular:
- (i) The ANKC Regular class of competition includes teams made up of any breed(s) of dog and/or mixed breeds and must be offered at every sanctioned competition.
  - (ii) A Non-Regular class (Pee-wee, Veterans, etc.), is any class other than the ANKC Regular class.

No dog shall be listed on more than one time sheet in any given class of competition. No dog shall be listed on the timesheets from more than one club at any given event. Dogs may not compete in more than one class at a Controlling Body sanctioned competition except:

- (i) When the competition's regular class is unlimited or;
  - (ii) When all entries received for a competition's limited entry regular class are accepted.
- (g) Following the competition, the affiliate club is to submit to the Controlling Body the original time sheets and entry forms, a Competition Results Form and competition records in accordance with Controlling Body rules.

### **Section 1.2 - Points**

Points towards Flyball titles will be awarded provided timesheets are signed by a Judge and Controlling Body Representative who are present and certifies that at least four (4) teams actually competed.

### **Section 1.3 - Format and Schedule**

The competition format and schedule shall be approved by the Controlling Body. The competition format includes:

- (i) Teams in each division along with the declared seed time of each team and the breakout time assigned to that division.
- (ii) Format of the competition, e.g. Round Robin with or without Single/Double elimination, and whether the two rounds are added together or not.
- (iii) Scoring – how wins and placings are determined; and how tie scores would be broken.

### **Section 1.4 - Seed Times and Breakout Penalties**

(a) All teams are required to provide a seed time on entry forms. Seeding times for a competition will be based on the fastest time recorded by a team during their last three sanctioned competitions. Any times recorded more than 4 (four) months before this date, are declared null and void.

A declared time to be used as a seeding time, may be submitted by the team captain at least 14 days prior to the competition, to be accompanied by a written justification which may be referred to the Controlling Body.

(b) New teams or teams which have not raced for 4 (four) months must provide a declared seed time and will be subject to the declared breakout rule. When a team uses a declared seedtime, the seedtime declared by the team becomes subject to its own 1(one) second breakout not the division breakout.

(c) Division break out time will be one (1) second faster than the fastest seedtime for each division (except Division I where no breakout applies). When manual judging is used (in the absence or failure of the Electronic Judging System), the breakout time will be two (2) seconds faster than the fastest seedtime for each division (except Division 1).

(d) When the first breakout occurs, the time is recorded on the timesheet with B/O written next to the time and the heat is awarded to the team that did not breakout. The breakout team gains one point if a clean run (4 dogs) and the opposing team gains one title point if a clean run (4 dogs) and one title points for the win. If the opposing team has not

completed a clean run it gains no title points. This is the same for the next two breakouts by the same team. After the third breakout, the team forfeits the right to place in the competition but does not forfeit the right to gain an ANKC title point if they complete a clean heat with 4 dogs. A team that has broken out three times in a competition can only win a maximum of one title point per heat completed cleanly with 4 dogs in the following heats. The breakout team is unable to win any further heats during this competition. If the opposing team finishes the heat they will be awarded one title point for a clean run (4 dogs) and an additional title point for a win. If the team does not have a clean run with 4 dogs they gains no ANKC points for that heat. Where a team breaks out and is eliminated from a round robin competition all teams racing the breakout team (before and after the breakout) will be awarded competition points for wins or ties against the breakout team. A team that has already broken out three times in a preceding round robin format cannot race in either single or double elimination racing to decide the placing of the competition.

### **Section 1.5 - Meaningless Heats**

Heats which are meaningless to the outcome of a sanctioned competition are not to be run just for the sake of allowing teams to accumulate more points toward Flyball titles.

## **CHAPTER 2 - RULES FOR COMPETITION**

### **Section 2.1 - Code of Ethics**

- (a) One of the objectives of the ANKC is to promote co-operation and good sportsmanship in the training and exhibition of dogs. Co-operation and good sportsmanship should not be recognised in passive observance, but as a way of life in training and competition. Participants shall at all times be courteous and friendly. At no time should they show displeasure with a dog, a Judge, exhibitor, Controlling Body Representative, sponsor, affiliate or spectator, in or out of the ring.

Never conduct yourself in a manner that would bring discredit to the sport of Flyball. As a participant, whether exhibitor, trainer, Judge, affiliate club or Controlling Body Representative, you typify the sport of Flyball.

- (b) Training and exhibiting shall be carried out by such methods that are in the best interest of the dog and the sport of Flyball.
- (c) Abuse or severe disciplining of a dog (e.g. shaking, smacking, kicking etc.) is not in the best interest of the sport of Flyball. Abuse may include the running of dogs that are not one (1) year of age.
- (d) Participants shall always follow the rules, showing knowledge and an understanding of the same.
- (e) Any individual or club may file a protest or prefer charges against another individual or club for alleged misconduct, in or out of the ring, prejudicial to the best interest of the sport of Flyball as provided for under Section 2.2. Protest filed during competition should be done in such as manner as not to bring discredit to the sport of Flyball.

## **Section 2.2 - Misconduct**

Misconduct shall include, but not be limited to, abusive or foul language, demonstration of dissatisfaction with a Judge's decision, inhumane treatment of a dog, demonstration of poor sportsmanship, wilful violation of the rules with the intent to gain an unfair advantage or any other behaviour or altercation that would leave a spectator or exhibitor with an unfavourable opinion of the sport of Flyball.

## **Section 2.3 - Amateur Competition**

The ANKC conducts amateur competitions.

## **Section 2.4 – Changing Teams**

(a) If a dog has raced in a Controlling Body sanctioned competition, the dog may not race with another club/team for 3 months (90 days). This does not apply when changing teams within a club (e.g. from Front Runners A team to Front Runners B team). Any deviation from this rule will result in the team being disqualified and having to run "non-competitive" and no ANKC points will be awarded to any dog in the team. Exceptions to the 90 day rule are as follows and must be approved by the Controlling Body:

- (i) The handler/dog has moved to another area.
- (ii) Team agrees to dissolve
- (iii) A new team is formed. Once the dog has joined a team, that dog may not run with another team, new or existing, for a period of 3 months (90 days). A club/team is considered to be "new" until they race in their first Controlling Body sanctioned competition.

A dog/team waiting for exemption approval from the Controlling Body may still enter a competition pending Approval.

## **Section 2.5 - Protest**

During competition, protests may only be lodged before the start of the next heat. Protests, which are not lodged before the start of the next heat must be submitted in writing to the Controlling Body. The Controlling Body will notify all parties of its decisions, recommendations and/or actions in accordance with their rules.

## **Section 2.6 - Record Times**

The minimum requirement for having an Australian record time recognised is to:

- (a) Have electronic timing;
- (b) A continuous video of the heat showing the time sheet after the completion of the heat. The video must be in line with the start finish line, with a clear view of the sensor panels, and the light tree. The continuous video must also have a date and the frame counter activated at the time the video evidence is taken.
- (c) All passes / exchanges must be clean to qualify for an Australian record.
- (d) The electronic judging system must not show any errors or faults and show the heat time after the green light for declaring the winner has been activated.
- (e) The heat should be timed with a stopwatch when the video is reviewed. The hand timing is to confirm that the tape is of the actual run in question.
- (f) To verify a new AFA/ANKC record time the Judge must verify the following using the appropriate form. Race lane length, jump placement, box throw, jump heights, and height dog measurement.

## CHAPTER 3 - EQUIPMENT

### Section 3.1 - Flyball Boxes

- (a) Each team shall supply a Flyball box.
- (b) All boxes are to have a mechanical (not electrical) pedal release mechanism.
- (c) The boxes may be painted or decorated as the team wishes.
- (d) The ball, when released, must have a free unobstructed flight of not less than 609.6mm (24 inches) from the point that the ball is released, in the direction of the start/finish line from all holes.
- (e) Boxes:
  - (i) Shall not exceed 609.6mm (24 inches) in width, nor 457.2mm (18 inches) from the bottom surface of the box excluding mat grabbing devices/materials and outdoor staking devices.
  - (ii) The body of the box shall not exceed (762mm) 30 inches in depth.
  - (iii) The dimensions do not include any platform the box loader uses to stand on.
  - (iv) Mat grabbing devices/materials shall not raise the box by more than one half inch;
  - (v) The box shall not exceed these dimensions at any time during racing (including any permanent attachments to the box, i.e. carrying handles, cocking devices).

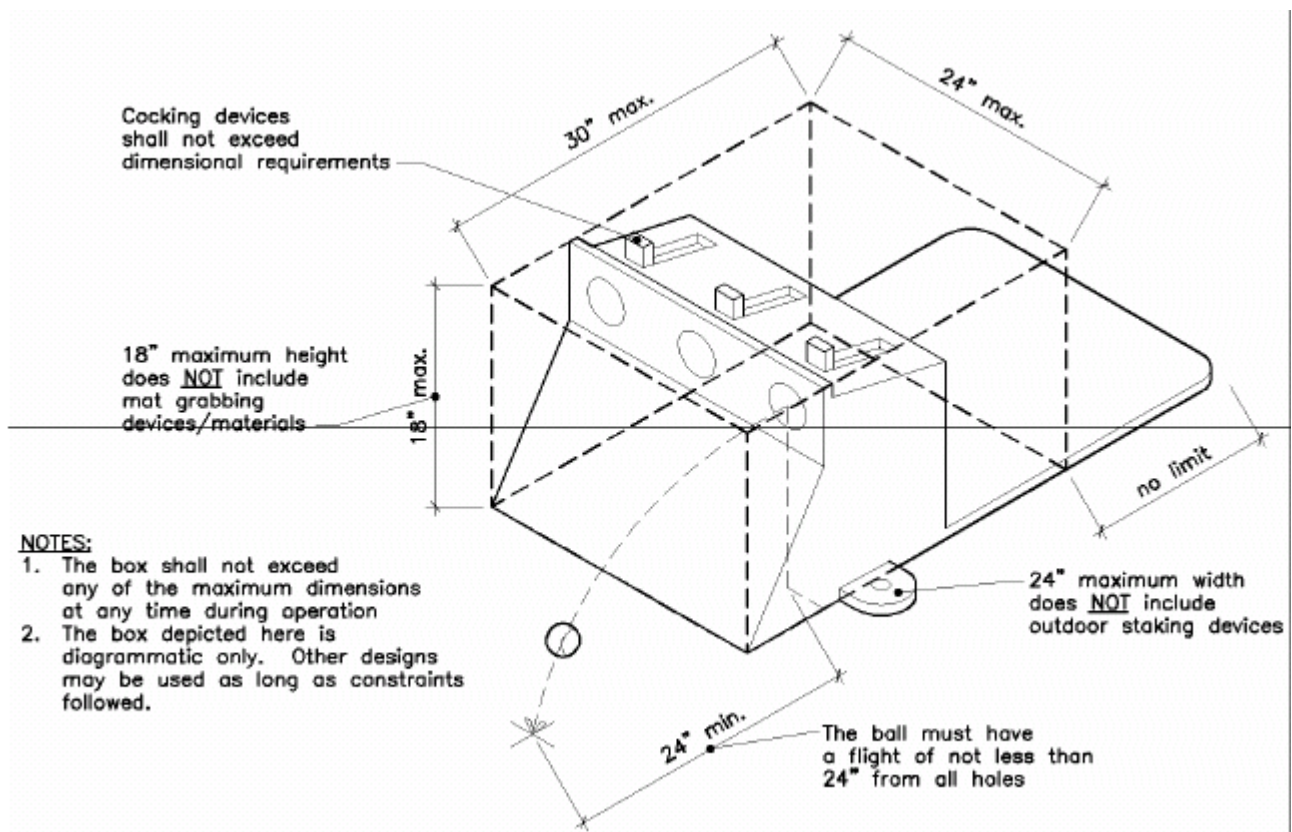

### Section 3.2 – Balls

Each team shall have its own supply of unpunctured, regulation tennis balls (any colour). Subject to the size and comfort of the dog, squash balls, racket balls, or approved balls may be used. Approved balls must function similar to a tennis ball (i.e. they must bounce and roll).

### Section 3.3 – Jumps

- (a) The affiliate club shall provide two sets of regulation (identical) jumps for the duration of the Flyball competition. Teams are asked to cooperate by lending equipment.
- (b) The jumps shall be solid flat white except for the uprights (posts), which may be any colour. The jumps shall have an inside width of 609.6mm (24 inches), with uprights (posts) not more than 914.4mm (36 inches) high nor less than 609.6mm (24 inches) high. Logos and/or lettering on the cross-boards will be permitted but must maintain a 50.8mm (2 inch) white border around all four edges inside the post.
- (c) Jump heights shall be set 127.0mm (5 inches) lower than the height at the withers of the smallest dog on the team (running not stand-by), to a minimum of 177.8mm (7 inches). Maximum jump height shall be 355.6mm (14 inches).
- (d) Jump heights shall be adjusted to 25.4mm (1 inch) increments, to the lowest whole number  $12 \frac{3}{4}$ " becomes 12".
- (e) The top of the jumps may be padded. Padding may not add more than  $\frac{1}{4}$  inch (6.3mm) to jump height.
- (f) Jump slats made of any material that are broken or bent must be removed from competition.
- (g) Jumps (including padding if present) shall be within  $\frac{1}{4}$ " inch tolerance for height.

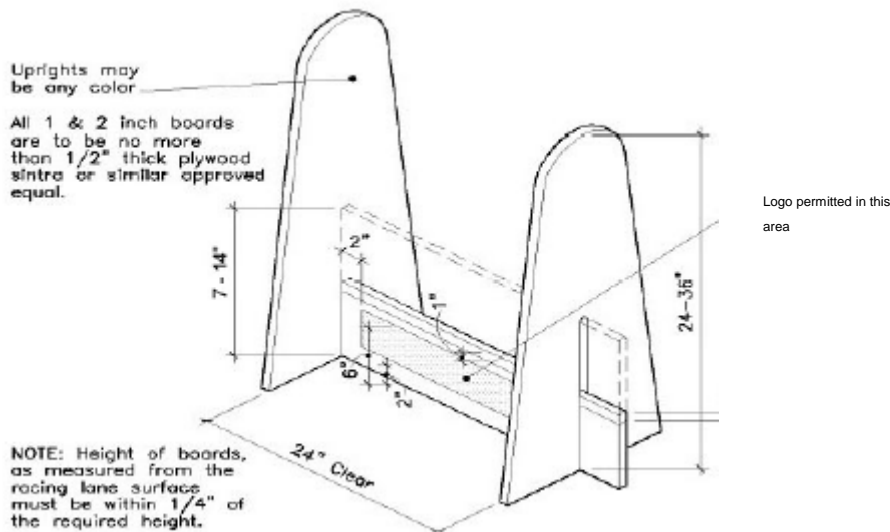

## CHAPTER 4 - RING SET-UP

### Section 4.1 – Footing

The affiliate club shall provide adequate non-slip footing on the racing lane, at the box and at the start/finish if racing indoors.

### Section 4.2 – Barriers

The affiliate club shall provide a barrier/backstop (minimum 609.6mm (24 inches) high) at the box end of the run, placed so as to prevent missed balls from rolling too far but placed so as not to prevent proper observation by the Judge or to obscure the spectators view.

A barrier (minimum 609.6mm (24 inches) high) shall extend between the boxes, up to 2 feet in front of the box placement line to minimise interference. Barriers shall not comprise jumping equipment.

### Section 4.3 - Ring Layout

- (a) There shall be a distance of 1.83m (6 feet) from the start/finish line to the first jump, 3.05m (10 feet) between each jump (four (4) in total) and 4.57m (15 feet) from the last jump to the front edge of the Flyball box. The start/finish line shall be clearly definable, bearing in mind the safety of the handlers and dogs.
- (b) Racing lanes are to be a minimum of 3m (10 feet) apart with a maximum of 6.1m (20 feet) apart.
- (c) The ring centre line shall be marked in solid or broken line by spray paint or, if indoors, by tape securely fastened in order to not be a trip hazard.
- (d) The minimum area required for two regulation lanes is 9.1m (30 feet) by 27.4m (90 feet).
- (e) The preferred ring size is at least 12.2m (40 feet) x 33.50m (110 feet) including entry and exit lanes on either side of start area. This is a recommendation only and competition organisers must ensure the minimum ring size is as per (d) above.
- (f) Each racing lane shall have a separate entry and exit gate.
- (g) In cases of racing lanes being placed on hard surfaces or carpet (such as indoor/outdoor carpet where rug burns are possible) each racing lane shall be matted at a minimum 1.4m (4 1/2 feet) on either side of the racing lane centre line for the length of the racing lane leading up to the first jump and an area from the last jump to the backstops.
- (h) Where sod, dirt, grass or similar surfaces are available matting shall not be required. All racing surfaces must be free of apparent contaminants.
- (i) The length of the racing lane shall include an area not less than 8.8m (29 feet) leading up to the start/finish line and an area behind the Flyball box and in front of the backstops to a minimum of 5 feet and that the backstops may protrude up to 2 feet in front of the box line.

- (j) The use of the start tapes/distance markers is allowable providing the following guidelines are used:
- (i) The tapes are to be placed 4 feet from the centre of the jump line to the right hand side. They must be set equally on each racing lane.
  - (ii) The tapes are not to be placed down the centre line between the two racing lanes.
  - (iii) The tapes are to be securely fastened adequately to prevent them being a trip hazard.

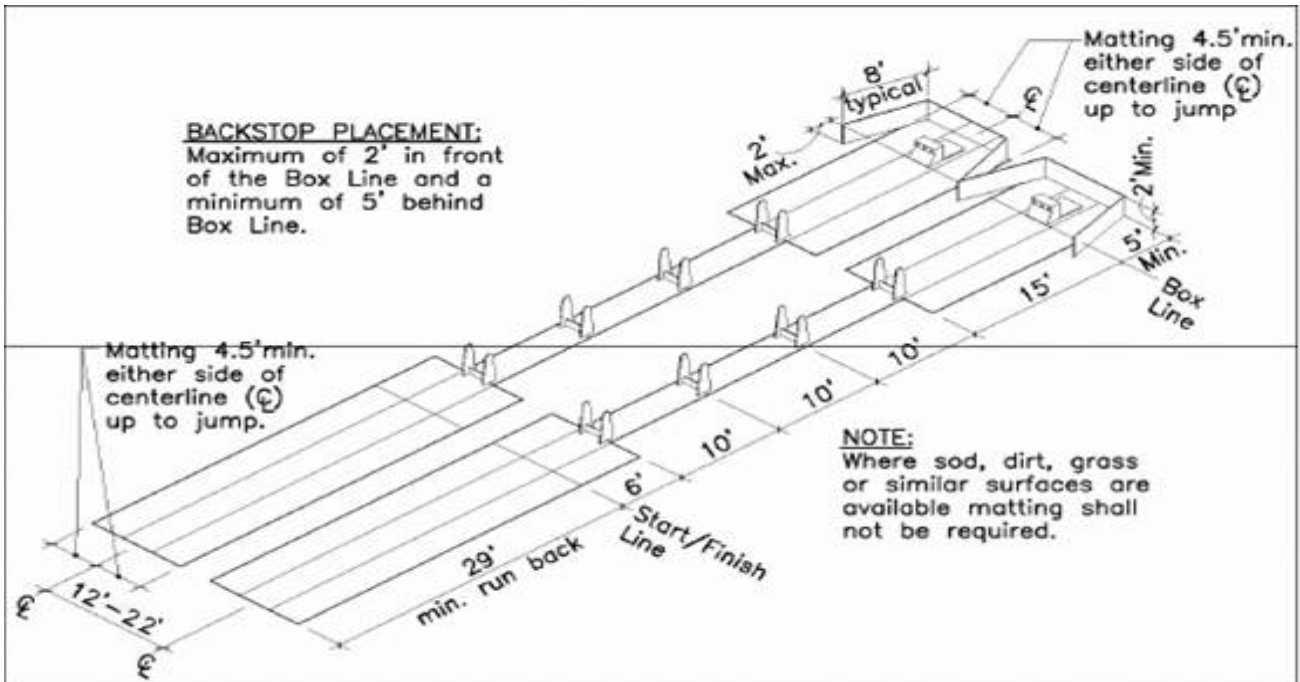

## CHAPTER 5 – TEAMS AND TIMESHEETS

- (a) Each team is to consist of a minimum of four (4) dogs and four (4) handlers, with a maximum of six (6) dogs and six (6) handlers, plus a box loader and, at the discretion of the team, up to two runners or two to pick up loose balls, set up knocked down jumps and to otherwise assist the team, providing doing so does not interfere with the Judge, nor the opposing team, nor in any way assist the dogs or violate the rules.
- (b) Each team is to have four (4) dogs running in each heat, with a maximum of two alternates as standbys close at hand. The reserve(s) may be used at the team's discretion or in the case of an injury. Substitutions may only be made at the end of each heat. Each dog on the team including the reserves must be declared prior to the competition. Once the competition has begun there will be no substituting of the dogs entered on the team.
- (c) The Time Sheet shall include the team name; the team captain's name, each dog's name, breed, dog's ANKC Registration Number and jump height; each handler's name and the name of the box loader.
- (d) For multiple entries of the same club/team, there will be no switching of dogs from one team to the other once the competition begins.
- (e) The dog's ANKC Registered Number shall be used to identify the dog throughout its racing career.

- (f) Any dog entered in a Controlling Body sanctioned competition without a valid ANKC Registered Number will result in forfeiture of all points and event placements for that team.
- (g) All Competitors will wear a tag displaying the ANKC Registered Number of the dog that the competitor is handling whilst racing in the ring at a sanctioned competition. The number must be of a suitable size to be easily read by the Judge, Stewards and Timekeepers.
- (h) The first offence of a handler's failure to comply shall receive a warning. A second offence or any offence thereafter during the competition will result in the loss of the heat.  
(See also Chapter 2 – section 2.4 Changing Teams and Chapter 7 – Reporting for Races).

## **Chapter 6 – MEASURING AND HEIGHT CARDS**

### **Section 6.1 - Measuring**

- (a) At the discretion of the team, dogs jumping less than 14 inches may be measured by the measuring Judge officiating at the competition during times designated by the affiliate club. A dog must be entered in the competition in order to have its height recorded on a Height Card Application form.
- (b) If the Judge determines that a team is not jumping at the correct height in a round robin format, the team shall forfeit all heats run at the improper jump height.
  - (i) In the case of an elimination format, the team shall be excused.
- (c) The Judge may at any time measure a dog.
- (d) Once the dog is measured, the Judge is under no obligation to re-measure the same dog in the same competition.
- (e) If a dog is re-measured and the measuring Judge determines a mistake has been made, the team shall in no way be penalized. However, the team will be required to jump the proper height for any remaining heats.
- (f) Any protest with respect to a dog's jump height must be verbalized to the Competition Organiser and/or the Controlling Body Representative within 30 minutes of the heat in question by the Captain of a competing team in that division or combined division.
- (g) Measurements are to be open to public observation.
- (h) Only one (1) handler per dog shall be allowed in the measuring area.
- (i) Aggression during measurement will not be tolerated and Section 9.3 (Aggressive Dogs) will be observed.
- (j) A team's height dog deemed to be "NOT MEASURABLE" by the measuring Judge may be excused from competition.

- (k) Height measurements are to be recorded and signed by the measuring Judge. In cases where multiple Judges are measuring, once a dog's height has been measured and recorded by either Judge that shall be the dog's official jump height for that competition, regardless of which ring the dog may run in.
- (l) The measurement area will be determined by the measuring Judge. The Judge shall select an appropriate measuring surface. Prior to measuring the first dog, and any time it is moved, the measuring device shall be calibrated to ensure accuracy. If the Judge determines that an appropriate measuring surface or that an ANKC approved measuring device is not available, measuring shall be for the competition only and not for an ANKC Height Card Application.
- (m) The dog's height shall be measured from the ground to the top of withers with the dog standing in an upright position as indicated by Illustration below. The handler may steady the dog if necessary, but shall not physically support the dog during the measuring process. The front legs will be vertical with the paws directly below the shoulders. The back legs will be positioned with the hocks perpendicular to the ground and spread no wider than the width of the dog. The dog's entire head is to be in an upright position above the level of the withers as shown in the following illustration. The dog may be measured up to 3 times. The height measurement shall go to the lowest height for the benefit of the dog.

**Dog standing properly to be measured.**

**NAFA Flyball Measuring Stance**

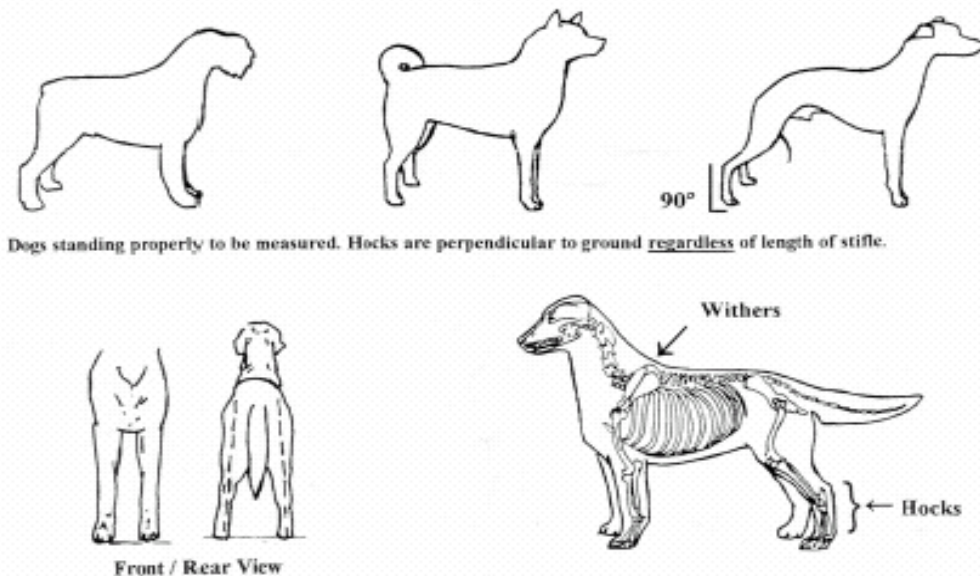

**Section 6.2 - Height Cards**

Height cards are optional and may be applied for by submitting a completed application form to the Controlling Body. There are a number of requirements:

- (i) Dog must race for at least 12 months before its first recorded measurement;
- (ii) Dog must be micro chipped prior to its first measurement (random checks may take place at competitions);

- (iii) The form must be presented to the Judge before the dog is measured;
- (iv) The form is considered complete when a dog has received the same measurement three (3) times by three (3) different Judges. Only one height card measurement may be attained per competition. The measuring Judge must be an approved ANKC Judge, but not necessarily officiating at the competition;
- (v) The microchip number must have been verified at least once;
- (vi) When the application form is complete, it must be forwarded to the Controlling Body with the appropriate application fee. The form will be verified and a height card issued;
- (vii) The height card must be presented at each competition; otherwise the dog is subject to normal measuring requirements;
- (viii) Height cards issued by the Controlling Body will be good for the life of the dog. Once a height card has been issued, additional cards for the same dog may not be applied for. Lost height cards can be replaced with an identical card for an appropriate fee.

## CHAPTER 7 – REPORTING FOR RACES

- (a) If one or more team members are more than five minutes late for the scheduled start of a race, all else being in readiness, the Judge may declare a forfeit by that team. This is a discretionary rule, since its main purpose is to avoid undue delays at the competition for spectators and competitors alike.
- (b) Teams that win by forfeit must complete the minimum required heats scheduled to qualify for points awarded in the round robin or to advance in double elimination competition. If another team is not available to compete the team shall race without an opponent.
- (c) Forfeiting teams that do not show just cause will be excused from the competition by the competition organiser and may be subject to further discipline. Forfeiting teams may not run any dogs in the heats that are forfeited. If a team forfeits a heat and then subsequently runs a dog(s) in violation of this rule, they will automatically be considered as Non-Competitive.
- (d) If a team has to forfeit when their "A" and "B" teams are in the same race, the faster team must run and the slower team must forfeit. If the faster team wishes to forfeit they will forfeit for the rest of the competition and run non-competitively.
- (e) Once a team declares non competitive, they cannot return to regular competition. From that point on, the team can no longer obtain ANKC points or competition points. Non-competitive teams may not run if the opposing team raises an objection with the Judge. Once teams declare themselves non competitive, they are ineligible for placement and shall be placed in the lowest seed of any eliminations. A team running as non-competitive is subject to all the rules of competition with the exception of the following:
  - (i) 3 or 4 dogs may be run in a heat;
  - (ii) False starts are not in affect;
  - (iii) Any jump height from 7" to 14" is allowed at the discretion of the team;
  - (iv) In the event a dog receives a flag, it may complete its run but not rerun;
  - (v) The Judge may excuse the team from the race for failure to comply with these conditions or other ANKC rules.

- (f) A club cannot enter a team in a Controlling Body sanctioned event to run non-competitive only.

## CHAPTER 8 – PRACTICE RUNS

- (a) There shall be a designated time period for warm-ups.
- (b) There shall be no practice or training in the ring for the duration of the competition except for the practice runs as permitted just prior to each race. Individuals may work with the Flyball box or on jumps outside the ring provided it does not distract other teams.
- (c) Training in the ring during the competition will mean a forfeit of that heat. When a team is delayed by a ring conflict, warm-ups shall not begin until both teams are present in the ring. Teams already present and waiting may set their jumps and place their box.
- (d) Only dogs listed on the team's timesheet are allowed to warm up. Each dog must have a valid ANKC Registered Number and be eligible to compete. Any dog(s) that warm up in violation of this rule will cause the forfeiture of all ANKC title points earned during the competition for all dogs on the timesheet. The team with the dog that violated this rule will also forfeit any competition placement.
- (e) Flat collars and harnesses are the only acceptable type of collar.
- (f) Where in the opinion of the Judge a dog's racing ability has been or may have been affected by the actions of another dog or handler by the way of interference, aggression, distraction or abuse, that dog may use the racing lane to practice after the incident for a period of time at the Judge's discretion and shall not be deemed as training in the ring after commencement of racing.

## CHAPTER 9 – RULES OF RACING

**(See also Section 1.4 Seed Times and Break Out Penalties)**

### Section 9.1 – Jump Heights

- (a) Jump heights shall be set at a minimum of five (5) inches lower than the height at the withers of the smallest dog on the team (running in that heat), to a minimum of seven (7) inches. Maximum jump height shall be fourteen (14) inches.
- (b) Jump heights shall be adjusted in one (1) inch increments, to the lowest whole number (11 and 3/4 inches becomes 11 inches).

### Section 9.2 – The Race

Each race consists of three, best three out of five or five heats which make one race.

#### **(a) The start:**

Dogs may start from a stationary or running start. When using a manual start (Judge's whistle), if any part of the dog's body, whether in the air or on the ground, or any part of the handler's body or their objects are over the line before the whistle

is blown, will be an infraction, to be called by line steward or Judge. When electronic starting lights are used, any part of the dog or handler's body or their objects breaking the beam before the start will constitute a false start and will be called by the EJS and Judge. The heat is to be restarted. If a second such infraction is called against the same team (for that heat) the dog must run again. If a second false start is called coincidental with the opposing teams first false start the heat is to be restarted.

**(b) The run:**

Dogs may start from a stationary or running start. Each dog is cross the start-finish line between the start gates, hurdle all four (4) jumps in succession, trigger the box, retrieve the ball from the box, return over all four (4) jumps and cross the start-finish line between the start gates with the ball in its mouth. Only when the first dog has reached the start/finish line with any part of it's body (on the ground or in the air), may the second dog reach the start/finish line with any part of it's body (generally this is a nose to nose pass at the start/finish line), and so on for all four (4) dogs as well as dogs that must run again. Early passes will be indicated by the Electronic Judging System (EJS) or in cases of EJS failure the line steward, thus the dog will be required to run again after the other dogs have run. If a dog reaches the start/finish line before the preceding dog has reached the start/finish line, or does not cross between the gates, or does not take every jump, or does not trigger the box, or takes the ball from the cup, or does not return with the ball, the dog must run again. If the handler or their object crosses the start/finish line during his/her dogs run, the dog must run again (with the exception of setting up a knocked down jump or retrieving a loose ball).

**(c) Knocked down jumps:**

A dog that knocks down a jump(s) during its run shall not be penalised, provided the dog(s) clear the jump as if it were standing. A "runner" or handler may set up knocked down jump(s) providing doing so does not interfere with it or guide the dog in any way.

**(d) Box Malfunction:**

The box loader shall indicate to the box steward and Judge when there is a box malfunction by standing in front of the box and waving their arms. The heat shall be stopped. The Judge is to examine the box. If, in the opinion of the Judge, the box has malfunctioned the heat shall be run again. If the box is found to be working then the heat shall be forfeited. If another box is not available and the box cannot be repaired in a reasonable time, the heat and any remaining heats are to be forfeited. If the box malfunctions a second time (or the spare box malfunctions) in the same race, the heat shall be forfeited and all remaining heats in that race shall be forfeited.

**(e) Intervention:**

Should the ball bounce back in the cup as the dog tries to catch it, the box loader may re-set the box for the dog to trigger it (without penalty). This is the only time at which the box loader is permitted to signal a dog to push the pedal.

**(f) Fouling:**

If a dog relieves itself in the racing ring at any time prior to the first heat or between heats, the dog's team forfeits the next heat.

**(g) Out of bounds/Out of play:**

The affiliate club shall specify the race area boundaries. If a ball bounces out of bounds and the dog retrieves the ball unaided, there shall be no penalty. If the dog is aided by a spectator, handler, box loader or other, the dog is to run again. Out of play shall be the same as if the ball were out of bounds, for example, if the ball becomes lodged or trapped inside the box.

**(h) Conduct of the box loader:**

Except during the warm up, to retrieve a loose ball or get a fresh supply of balls to load for the current heat, the box loader must remain in the upright position behind the box, and may offer verbal encouragement only, as long as such encouragement does not distract the opposing team. The box loader is to remain in position until the Judge determines the outcome of the heat. If, in the Judge's opinion, a box loader has violated any of these rules, his/her team may forfeit the heat. If, in the opinion of the Judge, a box loader assists a dog, except where provided for in the rules, the dog shall run again.

**(i) Interference:**

A dog or any team member interferes with the opposing team during a heat; the team causing the interference will forfeit the heat. This includes interference in the racing lane, in all in bound areas, and in the area where dogs are waiting to run. Interference is described as crossing the imaginary centre line and becoming a safety hazard to the dogs racing in the other lane and obstructing the other team's dog from running its race. If a team is interfered with, the team gets one bonus title point for the win and no points for completion. A dog chasing its team's loose ball into the other team's area is not necessarily interference.

An example of interference is when "Team A" and "Team B" were racing. A ball from "Team B" rolled across to the edge of "Team A's lane next to a jump. Two dogs from "Team A" ran by the ball without incident. The third dog however, stopped and picked up the ball. This is interference on "Team B" because the ball was from their lane. Even though the first two dogs ran past the ball, the ball was not supposed to be there and by its presence it prevented "Team A" from completing its run.

**(j) The finish:**

The first team to have all four (4) dogs successfully complete a run wins the heat. The finish shall be when the last of the four (4) dogs reaches the finish line with any part of its body, in the air or on the ground. A competition may be won due to default by the opposing team according to the rules of racing.

**(k) Distractions:**

Team members shall not distract the opposing team by bouncing balls, using a Flyball box at the end of the run, or by any other means nor by throwing any object for their dogs (i.e. balls, toys, Frisbees, dummies, gloves or treats). Team members are required to pick up loose balls. The first offence of any of these infractions shall receive a warning. A second offence or any offence thereafter during the race will result in the loss of the heat.

**(l) Broken boards:**

The heat shall not be stopped for broken boards, unless, in the opinion of the Judge, the dog(s) may be subject to injury. If the heat is stopped by the Judge to prevent a possible injury, the heat is to be restarted.

- (m) **Safety Hazards:**  
If, in the opinion of the Judge, a safety hazard exists during the running of the heat, the heat shall be stopped and rerun.
- (n) **Fouls:** Dogs that receive a foul must be rerun after the initial four dogs in the order they were fouled. Racing infractions requiring the rerunning of a dog include:
- (i) Early passes will be indicated by the EJS and the Line Steward and/or the Judge. When running without an EJS system, the line Steward will indicate an infraction;
  - (ii) Missed jumps;
  - (iii) Not carrying the ball over each jump in succession;
  - (iv) Does not trigger the box;
  - (v) Dog takes the ball from the cup without first triggering the box;
  - (vi) Does not carry the ball over the start/finish line;
  - (vii) Does not cross the start/finish line between the start gates;
  - (viii) Inappropriately assisted by the boxloader, spectator or handler;
  - (ix) A handler or their object crosses the start/finish line during the dog's run (with the exception of resetting knocked down jump(s) or retrieving loose ball(s)).
- (o) **Winner: Determining the winner of a heat:**
- (i) When a heat is judged using the Electronic Judging System, the winner of close heats shall be determined based on the Electronic Judging System times. When the times are within .003 of a second (for example, a time of 21.798 versus 21.801) the Judge shall declare the heat to be a tie;
  - (ii) When a heat is judged to be a tie with manual judging (in the absence or failure of the Electronic Judging System), the Judge shall confer with the line stewards and their decision as to the winner of the heat must be unanimous and shall be based on their visual view of the finish line, not on the stopwatches. If the Line stewards are not in agreement, the Judge shall declare a winner or declare the heat to be a tie.
- (p) **Determining the winner of an Elimination race format:**  
In the event that each team competing in an elimination race win an equal number of heats (due to dead heats or double DNF) an extra heat shall be run to determine the race winner.
- (q) **Determining the winner of a Round Robin competition:**  
The following competition points are awarded for each round robin race:
- (i) 2 points to the winning team;
  - (ii) 1 point for each team for tied races;
  - (iii) 0 points to the losing team. The team with the highest points at the end of the competition is the winner. In the event that two or more teams have the same number of competition points one of the following tie breakers are to be used:
- (i) a head to head run off between the teams with best two out of three heat format (where more than two teams are involved each must race the other with competition points recorded for each result)
- OR
- (ii) count back based first on head to head RACE wins during competition (where more than two teams are tied the count back for each team shall be the total RACE wins scored against all of the teams that are tied (the combined number of wins); if

two teams are still even the teams are compared on head to head heats; if two teams are still even – then average time using the 5 best completed head to head heats for each team (i.e. add the 5 best times of all completed heats run by each team head to head and divide by 5 to determine average completed heat time. Best average team wins.) If average time is even – then fastest heat time head to head decides the winner. Competition organisers must state which option is to apply in Competition Schedule and announce this at the start of Competition.

(r) **Signal Cards:**

Yellow, red or black cards will be used by Judges to indicate particular offences as follows:

**Yellow Card** – Indicates a formal “caution” for any of the following offences:

- (a) Not being courteous and friendly in manner.
- (b) Purposely delaying the restart of a heat.
- (c) For showing displeasure with a dog, a Judge, Stewards, Controlling Body Representative, affiliate club, sponsor, other exhibitor/s or spectator/s in or out of the ring. This includes showing dissent by word or actions.
- (d) Demonstration of poor sportsmanship.
- (e) For entering the ring to set up for a new race before the Judge has declared the previous race.
- (f) First offence for interference.

*Judges must:*

Hold up a Yellow playing card-sized card (preferably laminated) to signal an offence. Describe the specific offence to the Controlling Body Member and Team Captain and advise that it will be noted on Controlling Body’s member’s or their dog’s record. The Judge shall submit a report to the Controlling Body Representative.

**Red Card** – Indicates to a Controlling Body Member that they or their dog is to be “Sent Off” for 3 heats for any of the following offences:

- (a) Any other behaviour or altercation that would leave a spectator or exhibitor with an unfavourable opinion of the sport of Flyball.
- (b) Inhumane treatment of a dog (Includes racing a dog under 12 months of age).
- (c) Abusive or foul language.
- (d) Demonstration of dissatisfaction with a Judge’s decision. This includes approaching stewards or timekeepers to question them about the decision.
- (e) A Red Card will also represent a second incident of any offence listed under the yellow card.

*Judges must:*

Hold up a Red playing card-sized card (preferably laminated) to signal an offence. Describe the specific offence to the Controlling Body Member and Team Captain and advise that the offence will be noted on member’s or their dog’s record. The Judge shall submit a report to the Controlling Body Representative.

*Controlling Body Members must:*

Comply with Judges’ instructions to immediately exit the racing ring for the next 3 heats, regardless of racing order.

**Black Card** – Indicates to the Controlling Body Member that they or their dog is to be excused from the remainder of the competition for any of the following offences:

- (a) Wilful violation of the rules with the intent to gain an unfair advantage. (This includes sandbagging).
- (b) Aggression whether it be between dogs or handlers. It will also include a dog

that is suspected of aggression.

- (c) A Black Card is also used for a third incident of any offence listed under the Yellow Card and a second incident under the Red Card.

*Judges must:*

Hold up a Black playing card-sized card (preferably laminated) to signal an offence. Describe the specific offence to the Controlling Body Member and Team Captain. Advise the member that he/she or their dog is "Excused for the remainder of the Competition or Demonstration" and that the offence will be reported. The Judge shall submit a report to the Controlling Body Representative.

Controlling Body Members must:

Comply with Judges' instructions to immediately exit the racing ring for the remainder of the competition or Demonstration.

Black Card offences for member misbehaviour are serious offences. Black Card offences for dog aggression will result in the dog being automatically excluded from competition racing. The Controlling Body will deal with the offence/s under their Constitution and Rules.

### **Section 9.3 - Aggressive Dogs**

If a dog shows aggression toward another dog or handler, at any time during the competition, the Judge may excuse the dog from competing and a standby dog is to be used. The degree of aggression that warrants substitution is to be determined by the Judge. The Judge must report any dog excused from competition to the Controlling Body Representative in accordance with their Constitution and Rules.

### **Section 9.4 – Lamé Dogs, Bitches in Season, dogs Recovering from Surgery, Leg Wrapping**

Wrap on dog's legs may be used with the prior approval of the Judge. If, in the opinion of the Judge, a dog is lame, in season, recovering from surgery, obese or for a related reason should not compete; the same shall be excused from competition.

## **CHAPTER 10 – JUDGES**

### **Section 10.1- Judges**

One (1) Judge five (5) stewards and two (2) timekeepers shall officiate when two teams are running.

- (a) Two (2) stewards shall be positioned (sitting) at each team's starting line, facing each other; two (2) stewards are to be located at the box end, with a good view of the box loader, but not positioned (sitting) so as to interfere with or distract the dog; one (1) inbound steward shall be positioned (sitting) in the middle at the rear of the ring in the inbound area; two (2) timekeepers shall be positioned at the timekeeping table and the Judge shall also act as starter and referee.
- (b) The box stewards, line stewards, inbound steward and timekeepers shall remain stationary during each heat. Dogs may go around stewards and balls bouncing off a Judge, Steward or Timekeeper shall be deemed in play. The principle responsibility

of each box steward, each line steward, inbound steward and each timekeeper is to watch for violations in the racing lanes that they are assigned to and signal the Judge. Stewards, Timekeepers and Judges must not offer verbal encouragement to teams.

- (c) The Judge (starter and referee) shall be positioned between the racing lanes in the area between start/finish line and the starting dogs to start the heat. During the heat the Judge should be in a position to observe the handlers for any violations. Finally, if necessary, the Judge (starter and referee) should be in a position to assist the line stewards in determining winners of close heats. The Judge should always confer with the line stewards, the box stewards, the inbound steward and timekeepers before determining a winner. If necessary, a Judge shall reposition himself/herself in such a manner as not to distract the dogs competing. The Judge shall maintain a consistent starting cadence of approximately one (1) second intervals throughout the competition.
- (d) All Judges should have a clear understanding of the rules and shall be impartial.
- (e) Stewards shall indicate with a signal, which dogs must rerun. It is the handler's responsibility to note the signal and rerun his/her dog. If it is necessary to stop a heat, the Judge shall use a whistle.
- (f) Persons interested in becoming an approved ANKC Judge must complete successfully the Judges training program.
- (g) The minimum age for Judges, Stewards and Timekeepers is 18 years of age.

### **Section 10.2 - Judge's Guidelines**

- (a) Judges shall be friendly and courteous, even sympathetic, but above all impartial and firm. Judges must have a thorough understanding of the ANKC Rules and the sport of Flyball gained through personal experience.
- (b) The Judge's responsibility also extends to the exhibitors, to the affiliate club to the spectators and sponsors. A Judge must be arbiter and diplomat. A Judge must leave exhibitors and spectators with the feeling that each team was given an equal opportunity and no team was given an unfair advantage.
- (c) A Judge is not to engage in conversation with a disgruntled exhibitor. The Judge may excuse any person for breach of the Controlling Body's Rules.
- (d) Upon arriving at the site, a Judge shall immediately report to the competition organiser. A Judge shall be at their ring at least one half hour before the competition to check the ring, jumps, matting and backstops. If dogs are to be measured and boxes inspected before the competition, the Judge shall allow additional time as directed by the competition organiser.
- (e) The rules are a basic guide. They should not be considered a manual containing explicit direction for every possible situation. Judgment calls should be based on the experience, good character, fairness and consistency of the Judge. The intelligent application of discretionary authority demands a Judge exercise common sense, fairness and initiative. Above all else, the safety and welfare of the dogs and exhibitors shall be foremost.

Judges shall not assist teams during warm ups.

### **Section 10.3 - Judges and Stewards Duties**

- (a) Prior to the scheduled time for competition, the Judge shall inspect the ring. It must meet all the requirements of the ANKC Rules.
  - (h) The start/finish and centre line shall be clearly marked.
  - (ii) Jump placement, jump heights. A deviation of 6.35mm (1/4 inch) on the jump heights is considered minor and acceptable.
  - (iii) Backstops, barriers and box location shall be measured to make sure they meet the requirements of the regulations.
  - (iv) Each box shall be inspected by the panel of Judges and shall not be allowed if, in the opinion of the panel of Judges, the box has been constructed or altered in a manner that does not meet the box requirements.
- (b) Dogs that require measuring must be measured by the Judge prior to the start of the competition as per Section 6.1.
- (c) The Judge shall stop the heat for interference, fouling in the ring, aggression by a dog or handler and award that heat to the opposing team. The Judge shall also stop the heat for the first false start for which the heat is restarted.

#### Judges Reporting Policy:

The Judge or Controlling body Representative must report to the Controlling Body within 48 hours any dog or handler who is carded or excused from a competition or demonstration.

- (d) Timekeepers shall:
  - (i) Record which dogs participate in every heat using the ANKC Time Sheet.
  - (ii) Operate the EJS for the duration of each heat. They will ready the EJS before the start of each heat. The EJS will signify when there has been a false start or a bad changeover (pass). The timekeeper is required to press the manual foul for their assigned lane when a dog misses a jump, a dog does not carry the current ball across the start/finish line in its mouth, a dog does not trigger the box, a dog fouls in the ring, if a handler crosses the start/finish line during a heat (other than to set up a knocked down jump or to retrieve a loose ball) or other role violations for which a dog must run again.
  - (iii) Record any violations on the team's timesheet as per the Judge's instructions.
  - (iv) At the end of the heat the timekeeper is required to record on the timesheet the recalculated time given by the EJS after the EJS has declared the winner and record the winner.
  - (v) Check for breakouts and notify the Judge if a team has run a breakout time.
  - (vi) Mark when a manual time has been used due to EJS failure.
  - (vii) When manual timing is used instead of the EJS the timekeepers will become the backup timers to the Line Stewards. The Line Stewards time will be recorded on the timesheets.
- (e) Line Stewards shall:
  - (i) Record times on a stop watch for each heat run in case of EJS failure.
  - (ii) Signal with a flag when their assigned lane has fouled ie; when a dog misses a jump, a dog does not carry the current ball across the start/finish line in its mouth, a dog does not trigger the box, a dog fouls in the ring, if a handler crosses the start/finish line during a heat (other than to set up a knocked down jump or to retrieve a loose ball) or other role violations for which a dog

- must run again.
- (iii) Confer with the Judge following each heat to determine the winning team.
- (iv) When manual timing is used instead of the EJS the line steward becomes the main timer and is required to raise their flags for false starts, illegal passes in their assigned lane. They will also watch for close finishes.
- (f) Box Stewards Shall:
  - (i) Observe that the box loader or spectators do not assist the dog racing.
  - (ii) Signal to the Judge for box a malfunction (box loader to indicate to the box steward if the box malfunctioned).
  - (iii) Signal by raising their flag when a dog fouls in the ring, misses a jump, a dog does not trigger the box, or the box loader or spectator assists the dog in any manner that is not provided for in the Rules.
- (g) Inbound Steward shall watch for:
  - (i) Throwing of motivators or balls
  - (ii) Other distraction incidents
  - (iii) Aggressive incidents involving dogs and/or handlers
  - (iv) Incidents of Interference.
  - (v) Handler indiscretions and inform the Judge at the end of each heat if any of the above violations occurred.

## CHAPTER 11 – FLYBALL TITLES

### **Section 11.1 – Titles – Title Points system**

Teams racing in a Controlling Body sanctioned competition will receive 1 point towards their Flyball title for each dog racing in that heat when all four dogs complete the heat correctly without requiring any reruns. If that team wins the heat each dog running will receive another 1 point towards their Flyball title.

- (a) ANKC will award a certificate of achievement and title “Flyball Dog” (FD) to any dog receiving 5 points.
- (b) ANKC will award a certificate of achievement and title “Flyball Dog Excellent” (FDX) to any dog receiving 20 points.
- (c) ANKC will award a certificate of achievement and title “Flyball Dog Champion” (FDCH) to any dog receiving 50 points.
- (d) ANKC will award a certificate of achievement and title “Australian Flyball Champion” (AFCH) to any dog receiving 150 points.
- (e) ANKC will award a certificate of achievement and title “Flyball Master” (FM) to any dog receiving 400 points.
- (f) ANKC will award a certificate of achievement and title “Flyball Master Excellent” (FMX) to any dog receiving 700 points.
- (g) ANKC will award a certificate of achievement and title “Flyball Master Champion” (FMCH) to any dog receiving 1000 points.
- (h) ANKC will award a certificate of achievement and title “ONYX” Plaque, named after its first recipient, for any dog receiving 1300 points.
- (i) ANKC will award a certificate of achievement and title “Flyball Dog Grand Champion” (FDGCH) to any dog receiving 2000 points.
- (j) ANKC will award a certificate of achievement and title “JEDDAH” Award for any dog receiving 3000 points.

## CHAPTER 12 – RULE CHANGES

Any rule changes will be in consultation with the AFA.

## CHAPTER 13 – INVESTIGATIONS

Investigations will be done in accordance with the Controlling Body's Constitution and Rules.

### Appendix A - Guidelines for Dog Behaviour

These Guidelines details the process for reporting and dealing with dog behaviour including crossing, interference, distraction, suspected aggression and dog aggression. Controlling Body Members should note that it is their responsibility to ensure that their dogs are under control at all times and are adequately trained in correct behaviours necessary for Flyball racing.

#### Crossing:

Crossing is when a dog crosses the centreline but does not interfere with the other team in any way. The Judge will stop the race, the race will be awarded to the team which did not cross and a Yellow Card will be issued for the first offence, a Red Card for the second offence and a Black Card (and exclusion from the competition) for the third offence. The Incident report will cite 'crossing' as the type of incident. The Judge will have the discretion of a warning (in the back of the ring only) for the first offence.

#### Interference:

Interference is when a dog from one team interferes so that the dog in the other team is not able to finish the race. The Judge will stop the race and the race will be awarded to the team which did not interfere.

Crossing the centrelines is not necessarily interference. A dog chasing its own ball is not necessarily interference. A dog entering the racing area of the other team will be called as interference if for any reason the dog on the other team is unable to finish its run due to the actions of the dog crossing the centreline.

Interference will involve the issue of a Yellow Card for the first offence, a Red Card for the second offence at the same event and a Black Card (and exclusion from the Competition) for the third offence. The incident report will cite 'Interference' as the type of incident.

#### Distraction:

Team members shall not distract the opposing team by bouncing balls, using a Flyball box at the end of the run, or by any other means, nor throwing any object for their dogs (i.e. balls, toys, Frisbees, dummies, gloves or treats).

Team members are required to pick up loose balls.

The first offence of any of these infractions shall receive a warning. A second offence or any offence thereafter will result in the loss of the heat.

#### Aggression:

**Dog aggression is any behaviour meant to intimidate or harm a person or another animal.**

If a dog shows aggression toward another dog, animal handler official or Judge at any time during a Controlling Body Competition, either in the ring or outside the ring, a Judge or Controlling Body Representative may excuse the dog from the Event. If the incident occurred in the Ring and was observed by the Judge a Black signal card will be displayed.

The involved Judge or Controlling Body Representative has the sole right to determine the degree of aggression and whether or not a dog should be excused. Any action to excuse a dog for aggression must be reported in accordance with the Controlling Body's Constitution and Rules.

Aggressive behaviour may vary in severity. As a guide the following behaviours are potential demonstrations of aggression:

- Dog lunging, snapping or nipping at another dog or person with intent.
- Dog engaging in heavy growling and/or intimidating another dog by eyeballing with intent.
- Dog chasing and frightening another dog with intent.
- Dog chasing and biting another dog or person with or without a resultant sign of injury.
- Dog attacking another dog or person.

The words "With Intent" are designed to signify that the Judge or Controlling Body Representative must be of the opinion that the dog is showing behaviour that is designed to intimidate or actually harm another animal or person.

Any immediate appeal against the decision of a Judge at a Competition must be submitted before the start of the next heat. After that time appeals can only be lodged with the Controlling Body by written submission. Appeals against decisions of the Controlling Body Representative can only be in writing to the Controlling Body and dealt with in accordance with their Constitution and Rules.

**Appendix B – Forms****OFFICIAL FLYBALL ENTRY FORM**  
**Under the Rules of the Member Body of the ANKC**

Date:		
Name of Affiliate Club:		
Entry Fee:		
Catalogue:	Yes/No	
<b>Team Information</b>		
Team Name:		Club:
Captain	Box Loader:	
Postal Address:	Telephone:	
Email:		
Seed Time will be taken from current "Team Rankings" 14 days prior to competition date. A declared seed time may be submitted, but may be at least one (1) second slower than ranking and be accompanied by a clear explanation for the change.		
Declared Seed Time (in seconds):	Reason for Change:	
<i>Break Out Penalties apply to all ANKC Sanctioned competitions.</i> <i>Any dog entered in an Controlling Body's Sanctioned competition without an ANKC Registered Number will result in forfeiture of all points and event placements for that team.</i>		
<b>Declaration: All team members hereby apply to enter the foregoing exhibits in terms of an upon the conditions set out in the Controls Constitution and Rules by which they agree to be bound and they hereby certify to the correctness of the particulars endorsed hereon.</b>		
<b>(1) Dog's Name and Titles:</b>		
Breed:	Date of Birth:	Sex:
Registered Number:	Jump Height:	
Name of Exhibitor/Owner:	Telephone:	
Membership No:	Signature:	
<b>(2) Dog's Name and Titles:</b>		
Breed:	Date of Birth:	Sex:
Registered Number:	Jump Height:	
Name of Exhibitor/Owner:	Telephone:	
Membership No:	Signature:	
<b>(3) Dog's Name and Titles:</b>		
Breed:	Date of Birth:	Sex:
Registered Number:	Jump Height:	
Name of Exhibitor/Owner:	Telephone:	
Membership No:	Signature:	
<b>(4) Dog's Name and Titles:</b>		
Breed:	Date of Birth:	Sex:
Registered Number:	Jump Height:	
Name of Exhibitor/Owner:	Telephone:	
Membership No:	Signature:	
<b>(5) Dog's Name and Titles:</b>		
Breed:	Date of Birth:	Sex:
Registered Number:	Jump Height:	
Name of Exhibitor/Owner:	Telephone:	
Membership No:	Signature:	
<b>(6) Dog's Name and Titles:</b>		
Breed:	Date of Birth:	Sex:
Registered Number:	Jump Height:	
Name of Exhibitor/Owner:	Telephone:	

Membership No: \_\_\_\_\_ Signature: \_\_\_\_\_

<b>Competition:</b>		<b>Judge:</b>	
<b>Date:</b>		<b>Division:</b>	
<b>Team:</b>		<b>Seed Time:</b>	
<b>Captain:</b>		<b>Break Out Time:</b>	

	Dog's Name	CRN	Jump Height	Handler Name	Breed	Y D/H	R D/H	B D/H	Total Points
1									
2									
3									
4									
5									
6									

\*\*\*Please indicate four dogs for each heat – incorrect indication could result in no points being awarded\*\*\*

PLEASE DO NOT WRITE IN ANY GREYED AREA – THESE AREAS ARE TO BE USED BY THE COMPETITION ORGANISER ONLY

L	Heat	Versus	Dog	Time	M	4	Result	Any Use	Points
	1 of 3		1 2 3 4 5 6 _____		M	4	W L T _____		
	2 of 3		1 2 3 4 5 6 _____		M	4	W L T _____		
	3 of 3		1 2 3 4 5 6 _____		M	4	W L T _____		
	1 of 3		1 2 3 4 5 6 _____		M	4	W L T _____		
	2 of 3		1 2 3 4 5 6 _____		M	4	W L T _____		
	3 of 3		1 2 3 4 5 6 _____		M	4	W L T _____		
	1 of 3		1 2 3 4 5 6 _____		M	4	W L T _____		
	2 of 3		1 2 3 4 5 6 _____		M	4	W L T _____		
	3 of 3		1 2 3 4 5 6 _____		M	4	W L T _____		
	1 of 3		1 2 3 4 5 6 _____		M	4	W L T _____		
	2 of 3		1 2 3 4 5 6 _____		M	4	W L T _____		
	3 of 3		1 2 3 4 5 6 _____		M	4	W L T _____		
	1 of 3		1 2 3 4 5 6 _____		M	4	W L T _____		
	2 of 3		1 2 3 4 5 6 _____		M	4	W L T _____		
	3 of 3		1 2 3 4 5 6 _____		M	4	W L T _____		
	1 of 3		1 2 3 4 5 6 _____		M	4	W L T _____		
	2 of 3		1 2 3 4 5 6 _____		M	4	W L T _____		
	3 of 3		1 2 3 4 5 6 _____		M	4	W L T _____		
	1 of 3		1 2 3 4 5 6 _____		M	4	W L T _____		
	2 of 3		1 2 3 4 5 6 _____		M	4	W L T _____		
	3 of 3		1 2 3 4 5 6 _____		M	4	W L T _____		

<b>Place:</b>	1 <sup>st</sup>	2 <sup>nd</sup>	3 <sup>rd</sup>	4 <sup>th</sup>	5 <sup>th</sup>	6 <sup>th</sup>	<b>Best Time:</b>
<b>Judge:</b>							<b>AFA Rep:</b>

<b>Competition:</b>		<b>Judge:</b>	
<b>Date:</b>		<b>Division:</b>	
<b>Team:</b>		<b>Seed Time:</b>	
<b>Captain:</b>		<b>Break Out Time:</b>	

	Dog's Name	CRN	Jump Height	Handler Name	Breed	Y D/H	R D/H	B D/H	Total Points
1									
2									
3									
4									
5									
6									

\*\*\*Please indicate four dogs for each heat – incorrect indication could result in no points being awarded\*\*\*

PLEASE DO NOT WRITE IN ANY GREYED AREA – THESE AREAS ARE TO BE USED BY THE COMPETITION ORGANISER ONLY

L	Heat	Versus	Dog	Time	M	4	Result	Any Use	Points
	1 of 5		1 2 3 4 5 6	_____	M	4	W L T		
	2 of 3		1 2 3 4 5 6	_____	M	4	W L T		
	3 of 3		1 2 3 4 5 6	_____	M	4	W L T		
	1 of 3		1 2 3 4 5 6	_____	M	4	W L T		
	2 of 3		1 2 3 4 5 6	_____	M	4	W L T		
	3 of 3		1 2 3 4 5 6	_____	M	4	W L T		
	1 of 3		1 2 3 4 5 6	_____	M	4	W L T		
	2 of 3		1 2 3 4 5 6	_____	M	4	W L T		
	3 of 3		1 2 3 4 5 6	_____	M	4	W L T		
	1 of 3		1 2 3 4 5 6	_____	M	4	W L T		
	2 of 3		1 2 3 4 5 6	_____	M	4	W L T		
	3 of 3		1 2 3 4 5 6	_____	M	4	W L T		
	1 of 3		1 2 3 4 5 6	_____	M	4	W L T		
	2 of 3		1 2 3 4 5 6	_____	M	4	W L T		
	3 of 3		1 2 3 4 5 6	_____	M	4	W L T		
	1 of 3		1 2 3 4 5 6	_____	M	4	W L T		
	2 of 3		1 2 3 4 5 6	_____	M	4	W L T		
	3 of 3		1 2 3 4 5 6	_____	M	4	W L T		
	1 of 3		1 2 3 4 5 6	_____	M	4	W L T		
	2 of 3		1 2 3 4 5 6	_____	M	4	W L T		
	3 of 3		1 2 3 4 5 6	_____	M	4	W L T		

<b>Place:</b>	1 <sup>st</sup>	2 <sup>nd</sup>	3 <sup>rd</sup>	4 <sup>th</sup>	5 <sup>th</sup>	6 <sup>th</sup>	<b>Best Time:</b>
<b>Judge:</b>							<b>AFA Rep:</b>
<b>Competition:</b>							<b>Judge:</b>

---

## Appendix C – Round Robin Competition Format

Each team races every other team entered in their division an equal number of times.

Each race shall have three or five heats or be the best three out of five heats.

The following competition points are awarded for each race:

- (I) 2 points to the winning team;
- (ii) 1 point for each team for tied races;
- (iii) 0 points to the losing team

Place are determined by the number of points awarded to each team.

### Round Robin Format:

<b>3 Team</b>	-	Allow 30 Minutes for races
<b>4 Team</b>	-	Allow 1 Hour for races
<b>5 Team</b>	-	Allow 1 Hour and 20 Minutes for races
<b>6 Team</b>	-	Allow 2 Hours and 10 Minutes for races
<b>7 Team</b>	-	Allow 3 Hours for races
<b>8 Team</b>	-	Allow 4 Hours for races
<b>9 Team</b>	-	Allow 5 Hours and 10 Minutes for races

## ROUND ROBIN RACE SCHEDULES

### 3 Team Round Robin

Race 1	3	vs	1
Race 2	2	vs	3
Race 3	1	vs	2

**Allow 30 Minutes for Races**

### 4 Team Round Robin

Race 1	4	vs	1
Race 2	2	vs	3
Race 3	1	vs	3
Race 4	4	vs	2
Race 5	3	vs	4
Race 6	1	vs	2

**Allow 1 Hour for Races**

### 5 Team Round Robin

Race 1	5	vs	2
Race 2	4	vs	1
Race 3	3	vs	5
Race 4	2	vs	4
Race 5	1	vs	3
Race 6	4	vs	5
Race 7	2	vs	3
Race 8	5	vs	1
Race 9	3	vs	4
Race 10	1	vs	2

**Allow 1 Hour and 20 Minutes  
for Races**

### 6 Team Round Robin

Race 1	2	vs	3
Race 2	6	vs	1
Race 3	4	vs	5
Race 4	3	vs	6
Race 5	4	vs	2
Race 6	5	vs	1
Race 7	2	vs	6
Race 8	1	vs	4
Race 9	5	vs	3
Race 10	6	vs	4
Race 11	2	vs	5
Race 12	3	vs	1
Race 13	5	vs	6
Race 14	4	vs	3
Race 15	1	vs	2

**Allow 2 Hours and 10  
Minutes for Races**

### 7 Team Round Robin

Race 1	1	vs	4
Race 2	2	vs	5
Race 3	3	vs	6
Race 4	4	vs	7
Race 5	5	vs	1
Race 6	6	vs	2
Race 7	7	vs	3

Race 8	1	vs	3
Race 9	5	vs	7
Race 10	2	vs	4
Race 11	6	vs	1
Race 12	3	vs	5
Race 13	7	vs	2
Race 14	4	vs	6
Race 15	7	vs	1
Race 16	2	vs	3
Race 17	4	vs	5
Race 18	6	vs	7
Race 19	3	vs	4
Race 20	5	vs	6
Race 21	1	vs	2

**Allow 3 Hours for Races**

### 8 Team Round Robin

Race 1	4	vs	8
Race 2	3	vs	7
Race 3	2	vs	6
Race 4	1	vs	5
Race 5	6	vs	1
Race 6	8	vs	3
Race 7	2	vs	5
Race 8	4	vs	7
Race 9	3	vs	6
Race 10	5	vs	8
Race 11	7	vs	2
Race 12	1	vs	4
Race 13	8	vs	2
Race 14	4	vs	6
Race 15	7	vs	1
Race 16	3	vs	5
Race 17	6	vs	8
Race 18	2	vs	4
Race 19	5	vs	7
Race 20	1	vs	3
Race 21	8	vs	1
Race 22	6	vs	7
Race 23	4	vs	5
Race 24	2	vs	3
Race 25	7	vs	8
Race 26	5	vs	5
Race 27	3	vs	4
Race 28	1	vs	2

**Allow 4 Hours for Races**

### 9 Team Round Robin

Race 1	1	vs	9
Race 2	5	vs	7
Race 3	4	vs	8
Race 4	3	vs	6
Race 5	7	vs	9
Race 6	8	vs	2
Race 7	5	vs	3
Race 8	6	vs	1
Race 9	2	vs	4
Race 10	9	vs	5
Race 11	6	vs	8
Race 12	1	vs	7
Race 13	3	vs	2
Race 14	5	vs	4
Race 15	8	vs	1
Race 16	6	vs	7
Race 17	2	vs	9
Race 18	4	vs	3
Race 19	2	vs	7
Race 20	1	vs	5
Race 21	3	vs	9
Race 22	4	vs	6
Race 23	8	vs	9
Race 24	7	vs	3
Race 25	4	vs	1
Race 26	6	vs	2
Race 27	5	vs	8
Race 28	6	vs	9
Race 29	7	vs	4
Race 30	5	vs	2
Race 31	1	vs	3
Race 32	9	vs	4
Race 33	8	vs	7
Race 34	5	vs	6
Race 35	3	vs	8
Race 36	2	vs	1

## Appendix D – Elimination Competition Format

Each race shall have three or five heats or be the best three out of five heats

### Single Elimination Formats:

<b>4 Team</b>	-	Allow 40 minutes
<b>5 Team</b>	-	Allow 50 minutes
<b>6 Team</b>	-	Allow 1 hour
<b>7 Team</b>	-	Allow 1 hour
<b>8 Team</b>	-	Allow 1 hour and 10 minutes
<b>9 Team</b>	-	Allow 1 hour and 20 minutes
<b>10 Team</b>	-	Allow 1 hour and 30 minutes

### Double Elimination Formats:

<b>3 Team</b>	-	Allow 40 minutes for races
<b>4 Team</b>	-	Allow 50 minutes for races
<b>5 Team</b>	-	Allow 1 hour and 10 minutes
<b>6 Team</b>	-	Allow 1 hour and 30 minutes for races
<b>7 Team</b>	-	Allow 1 hour and 45 minutes
<b>8 Team</b>	-	Allow 2 hours for races
<b>9 Team</b>	-	Allow 2 hours and 20 minutes for races
<b>10 Team</b>	-	Allow 2 hours and 40 minutes for races
<b>11 Team</b>	-	Allow 3 hours for races
<b>12 Team</b>	-	Allow 3 hours and 10 minutes for races
<b>13 Team</b>	-	Allow 3 hours and 30 minutes for races
<b>14 Team</b>	-	Allow 3 hours and 45 minutes
<b>15 Team</b>	-	Allow 4 hours for races

### 3 TEAM DOUBLE ELIMINATION

Allow 40 Minutes For Racing

Team On Top On The Left

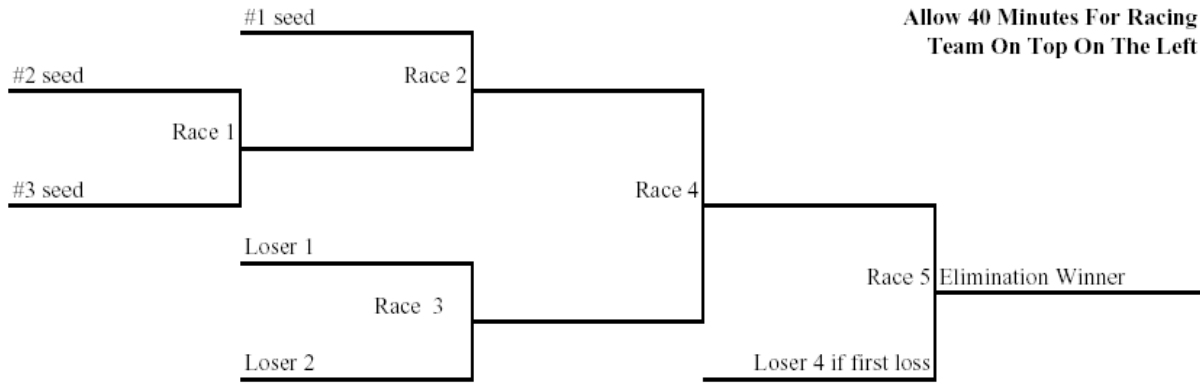

### 4 TEAM DOUBLE ELIMINATION

Allow 50 Minutes For Racing

Team on Top On The Left

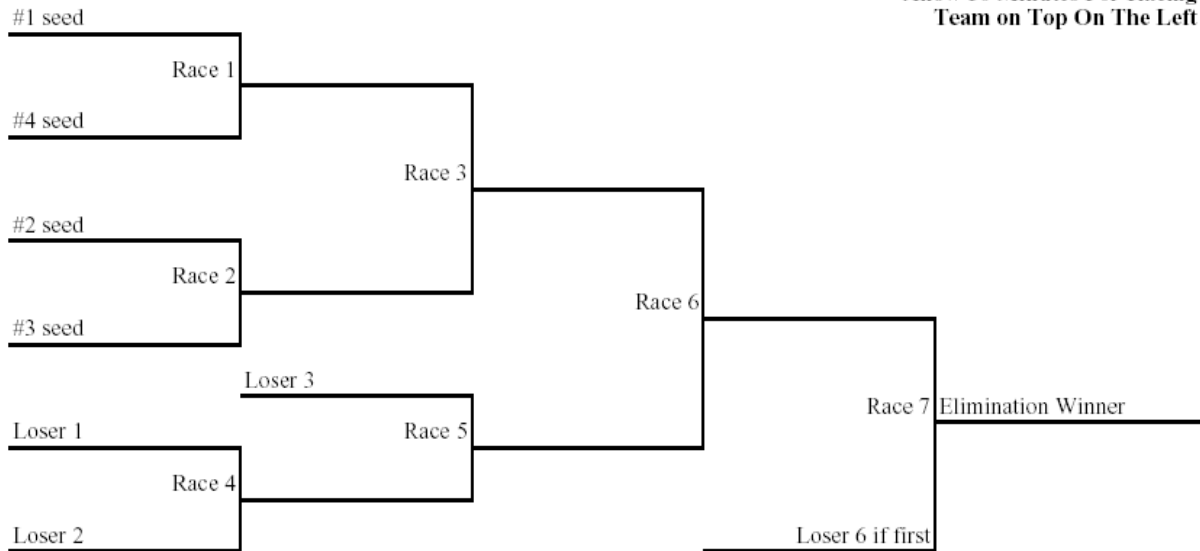

# 5 TEAM DOUBLE ELIMINATION

Allow 1 hr And 0 Minutes

Team On Top On The Left

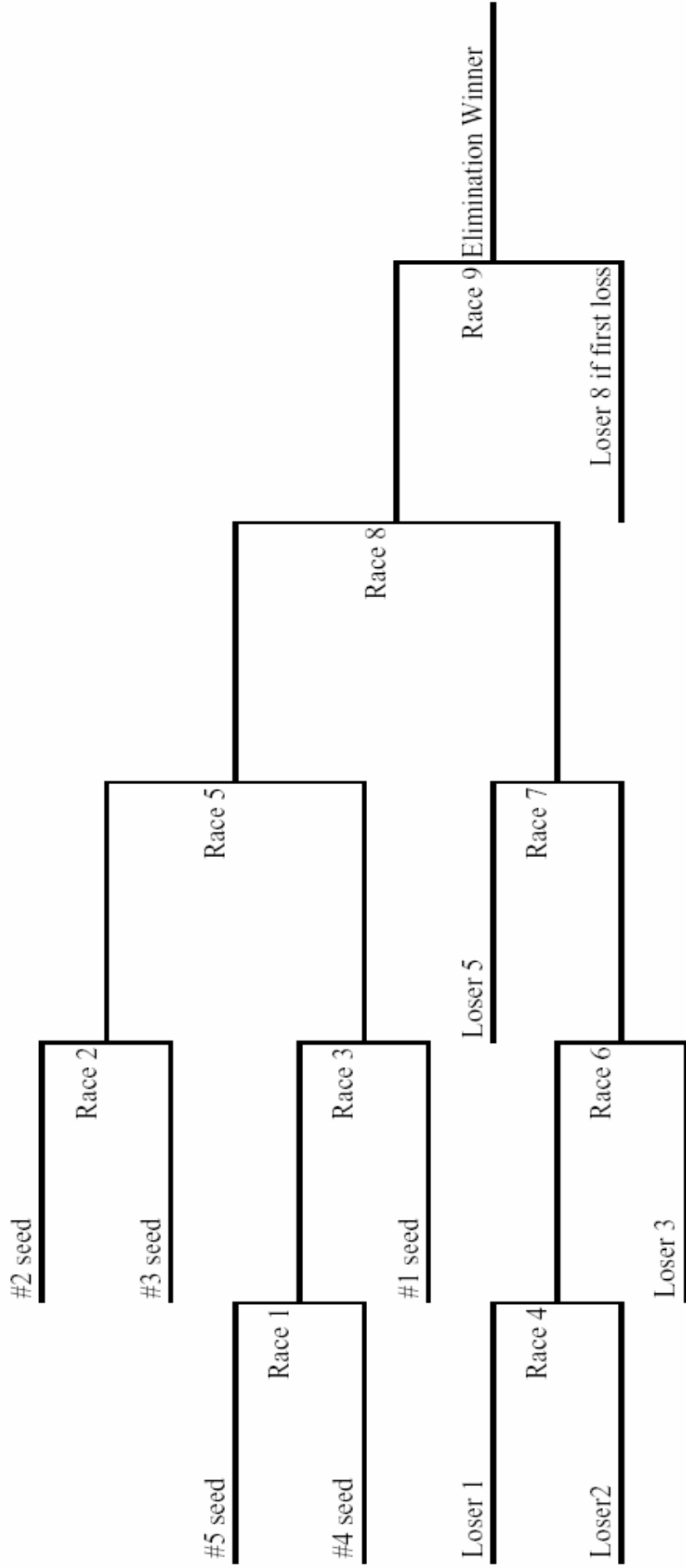

# 6 TEAM DOUBLE ELIMINATION

Allow 1 hr And 0 Minutes For Racing  
Team On Top On The Left

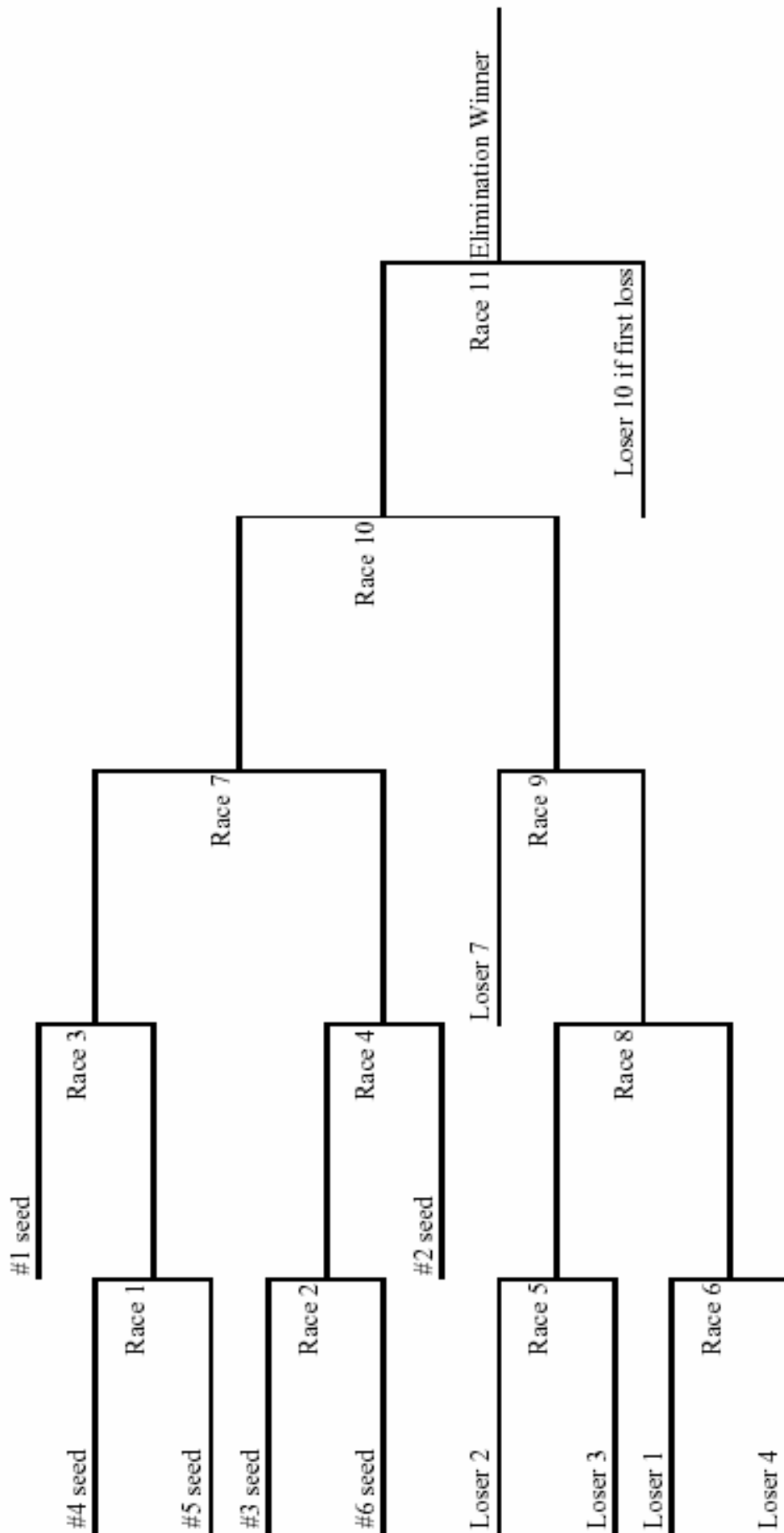

# 7 TEAM DOUBLE ELIMINATION

Allow 1 hr And 5 Minutes For Racing  
Team On Top On The Left

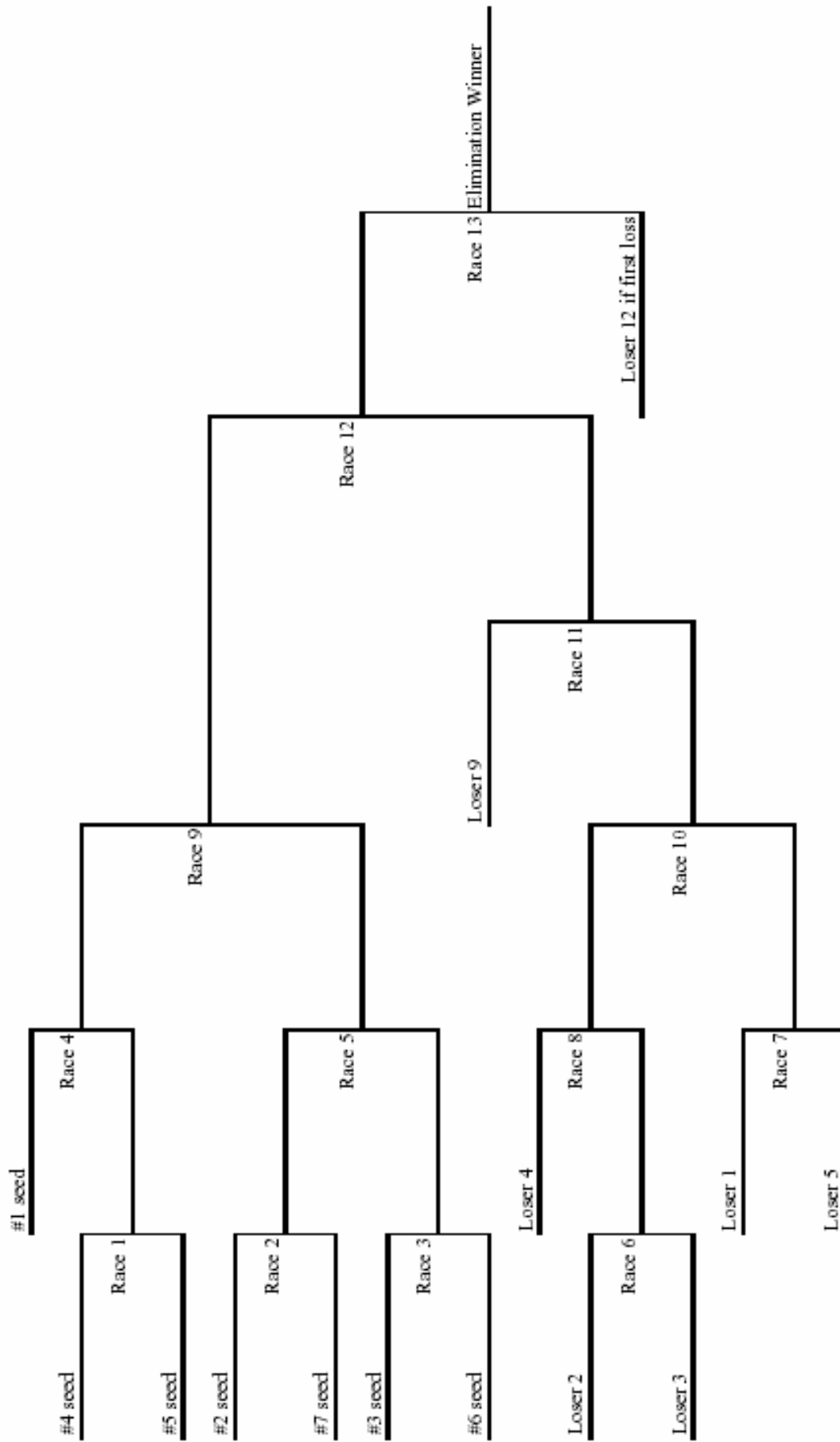

# 8 TEAM DOUBLE ELIMINATION

Allow 2 Hours for Racing

Team on top on the left

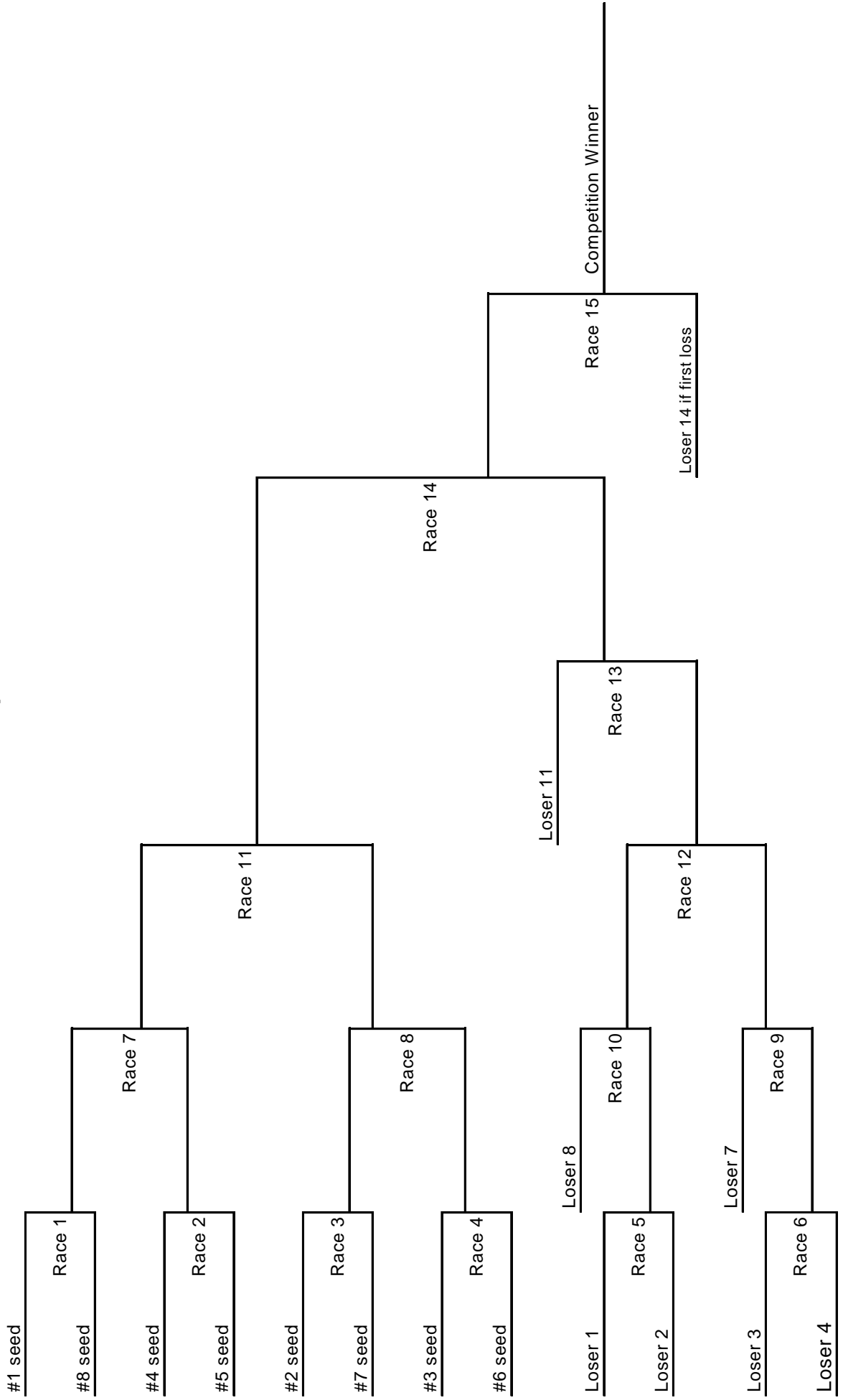

**9 TEAM DOUBLE ELIMINATION**  
 Allow 2 Hours and 20 Minutes for Racing  
 Team on top on the left

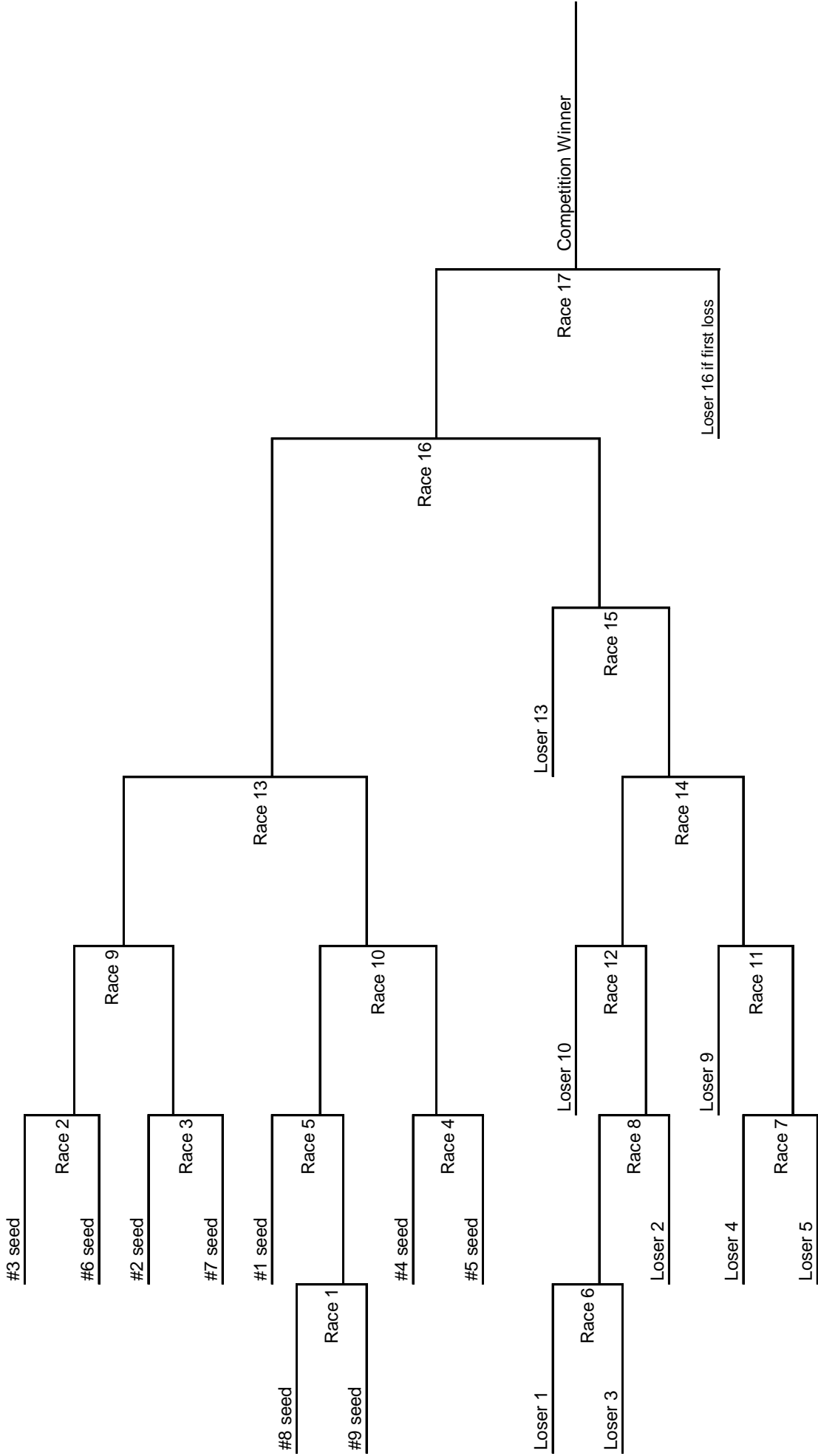

**10 TEAM DOUBLE ELIMINATION**  
 Allow 2 Hours and 40 Minutes for Racing  
 Team on top on the left

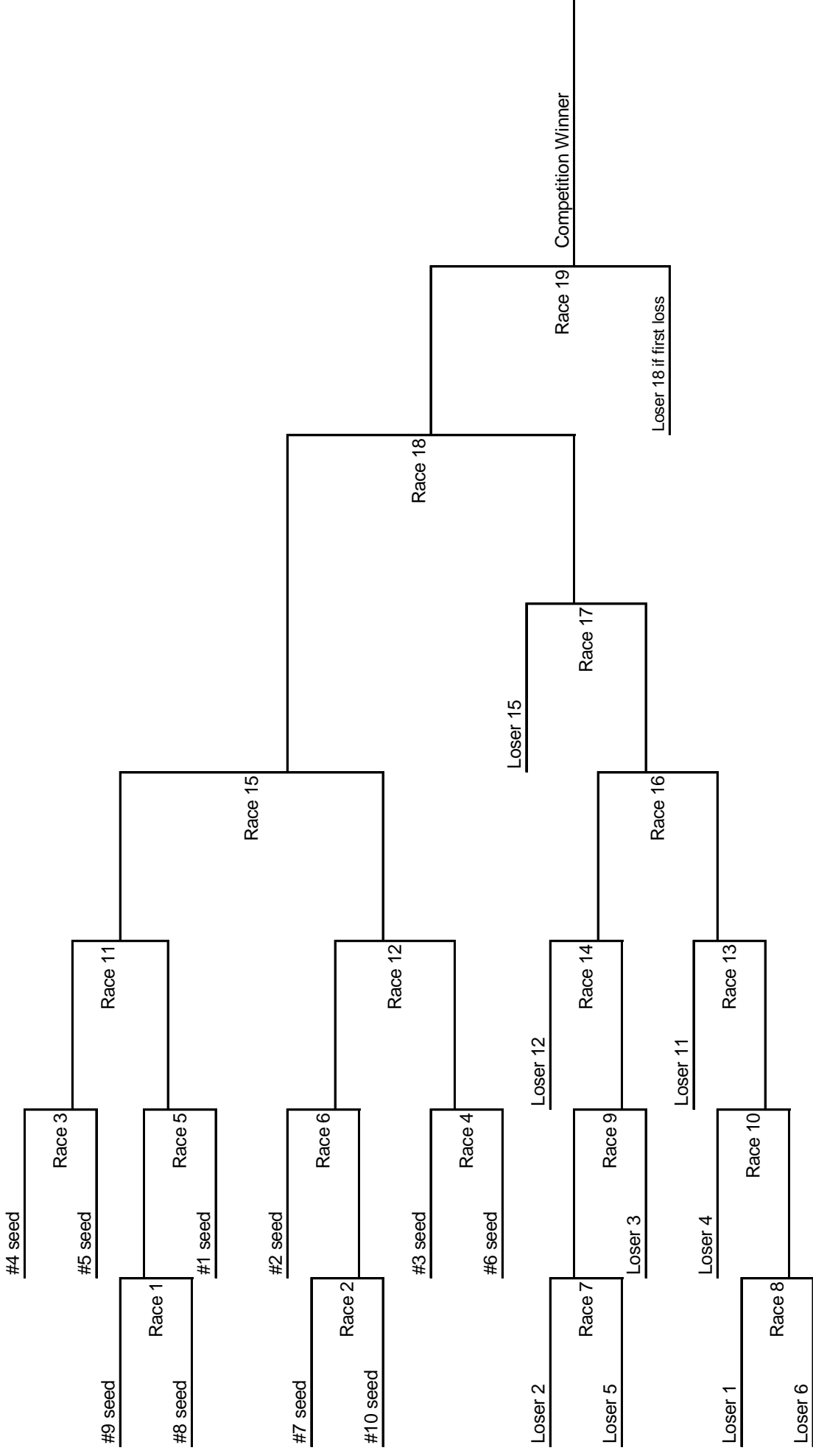

# 11 TEAM DOUBLE ELIMINATION

Allow 3 Hours for Racing

Team on top on the left

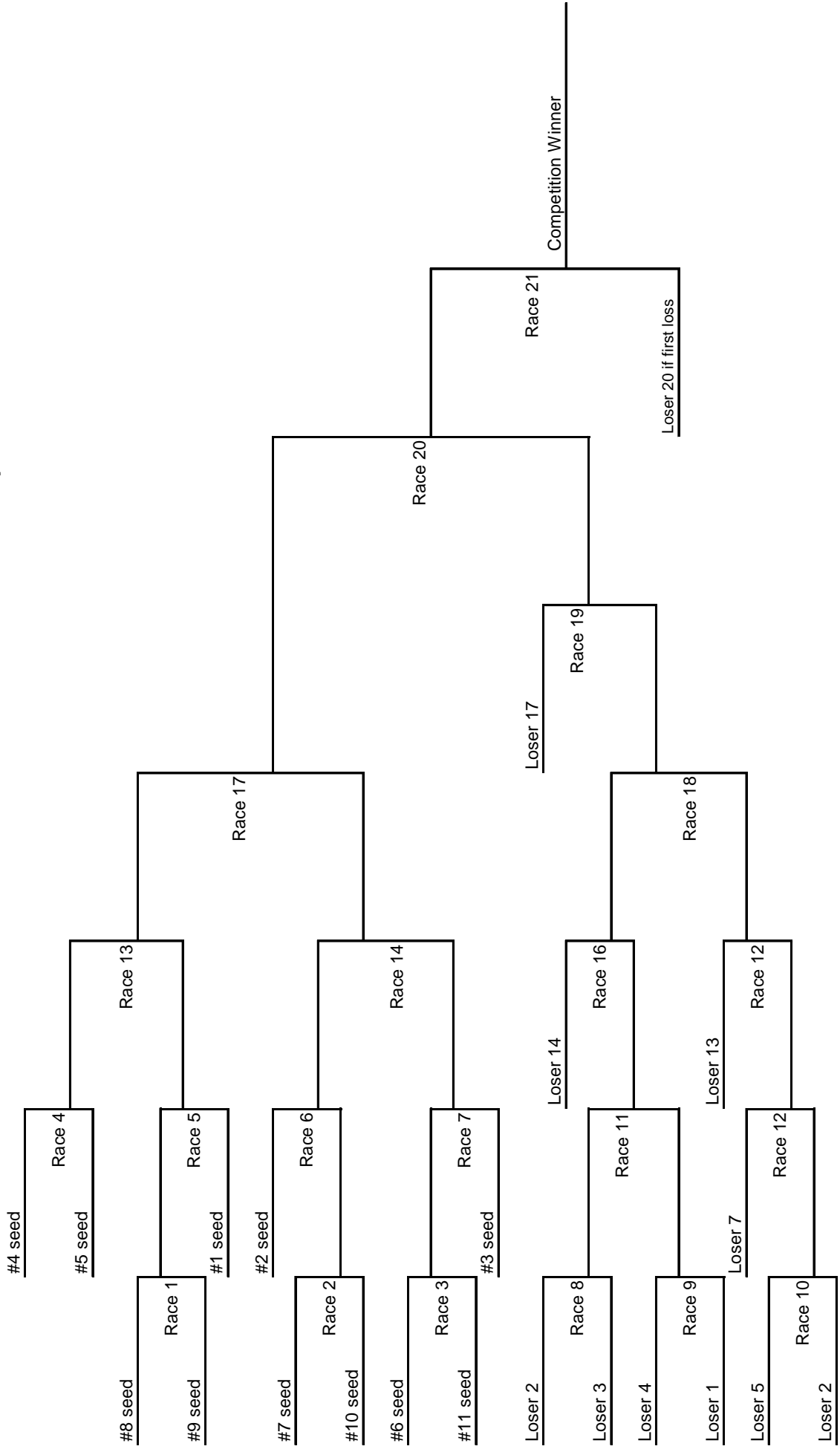

**12 TEAM DOUBLE ELIMINATION**  
 Allow 3 Hours and 10 Minutes for Racing  
 Team on top on the left

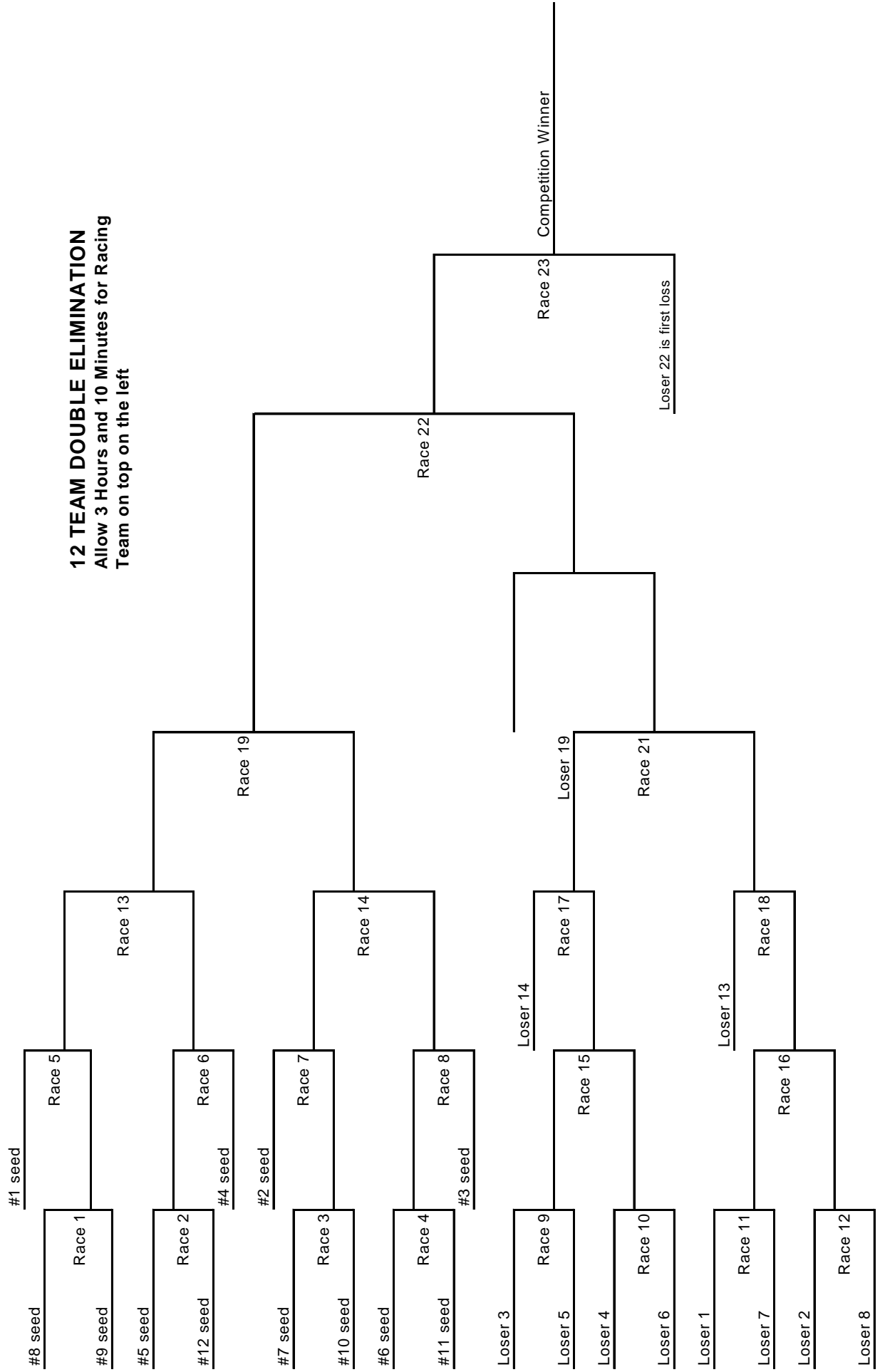

**13 TEAM DOUBLE ELIMINATION**  
 Allow 3 Hours and 30 Minutes for Racing  
 Team on top on the left

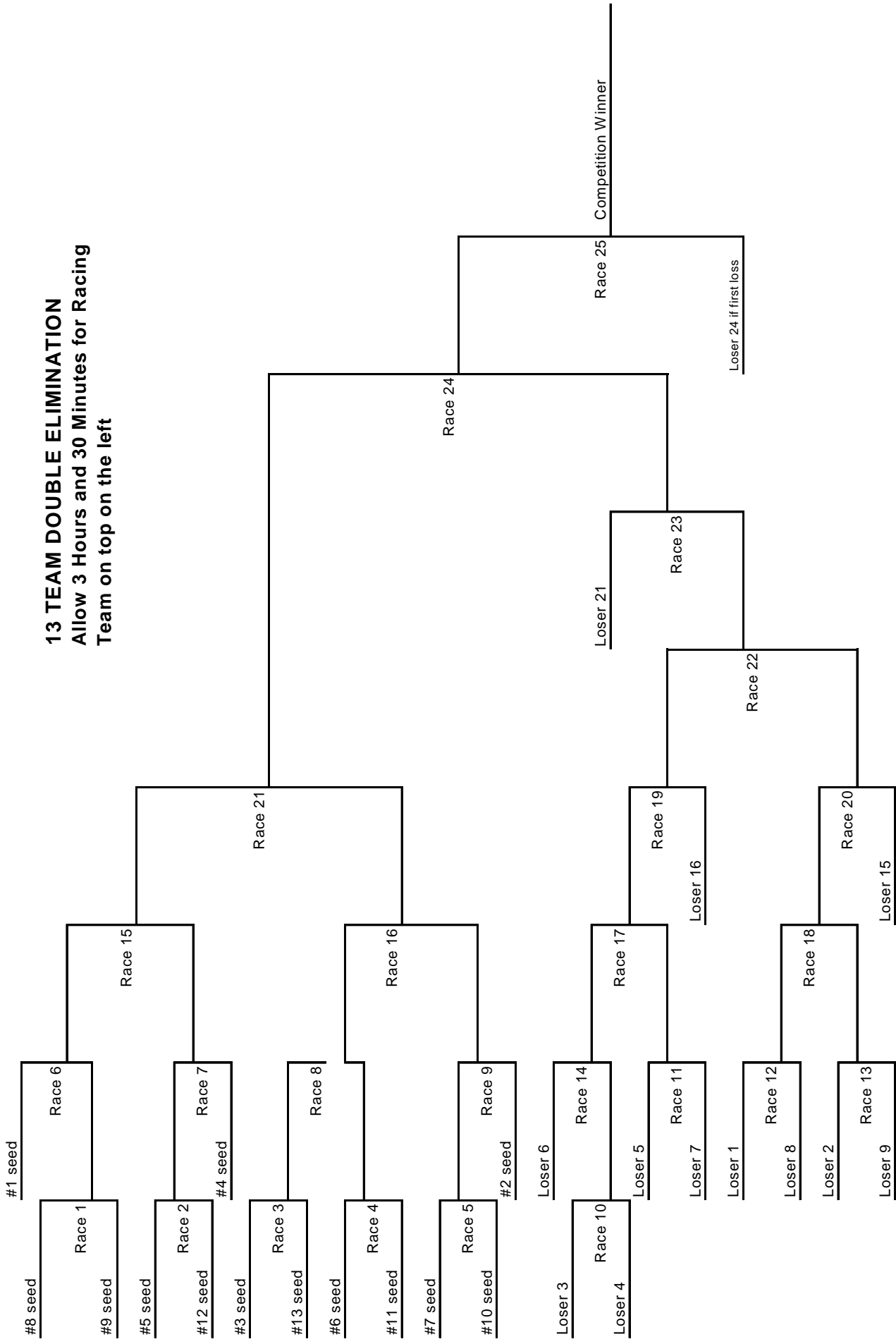

**14 TEAM DOUBLE ELIMINATION**  
 Allow 3 Hours and 45 Minutes for Racing  
 Team on top on the left

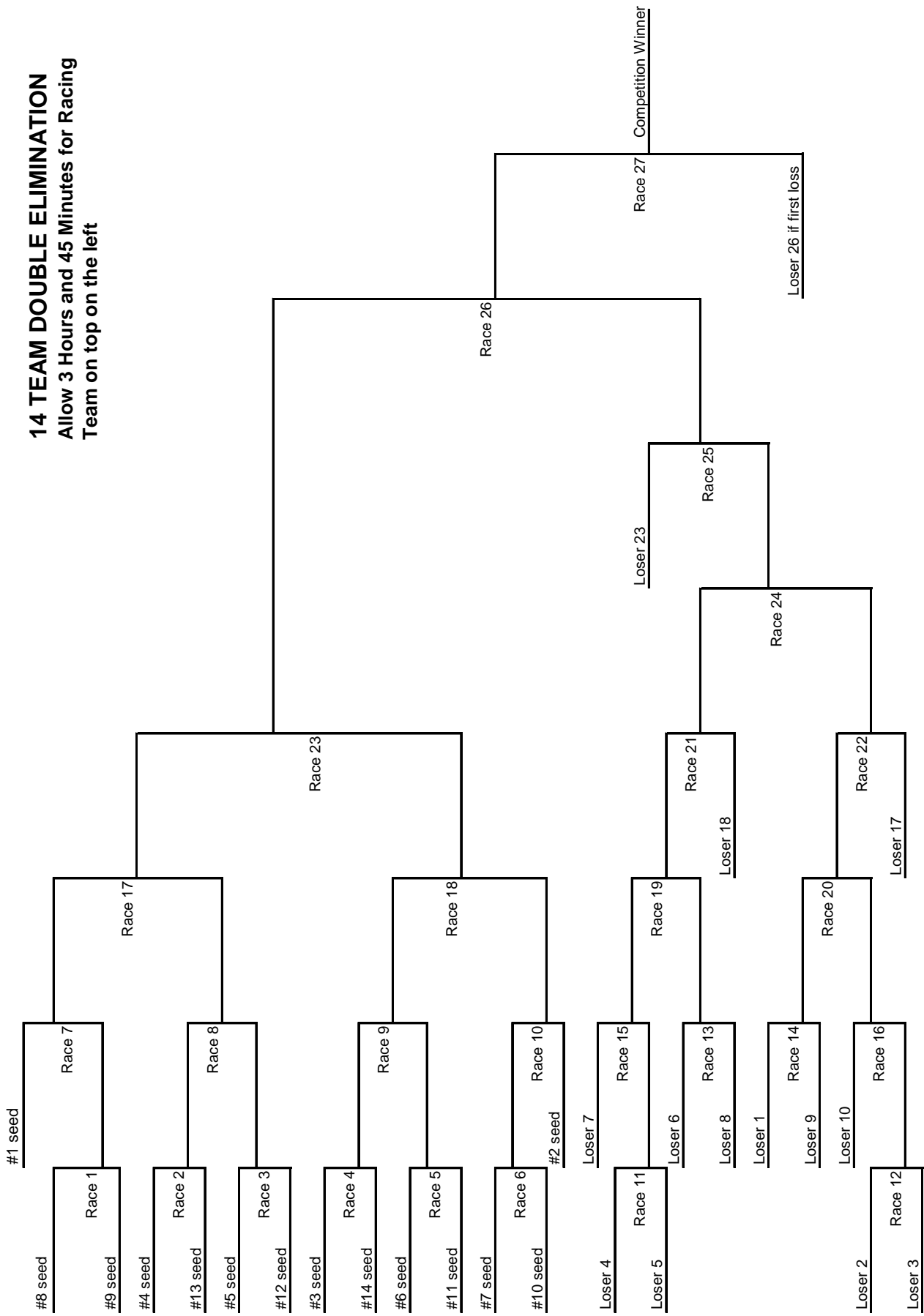

# 15 TEAM DOUBLE ELIMINATION

Allow 4 Hours for Racing  
Team on top on the left

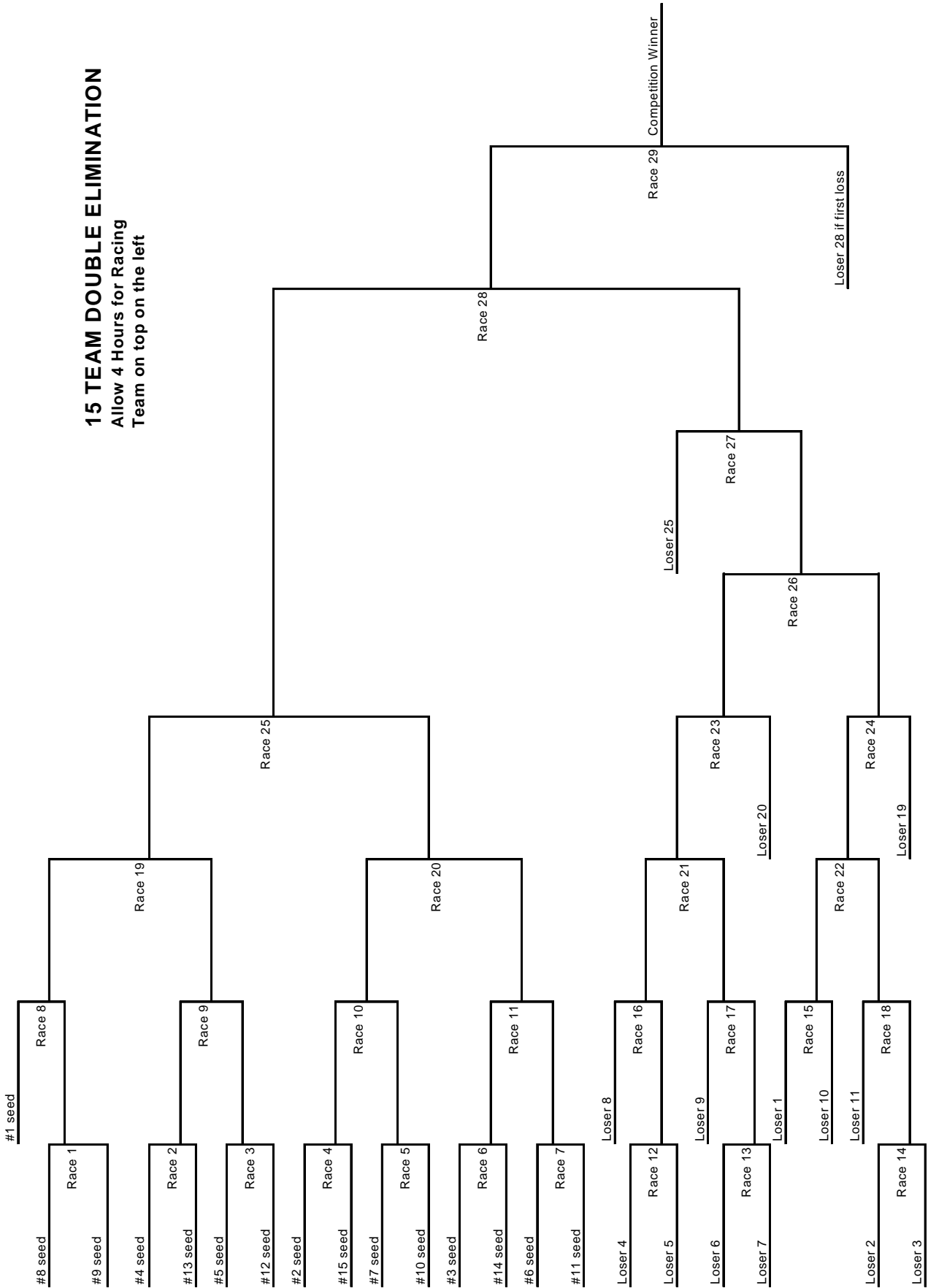



#### 4 Team Single Elimination

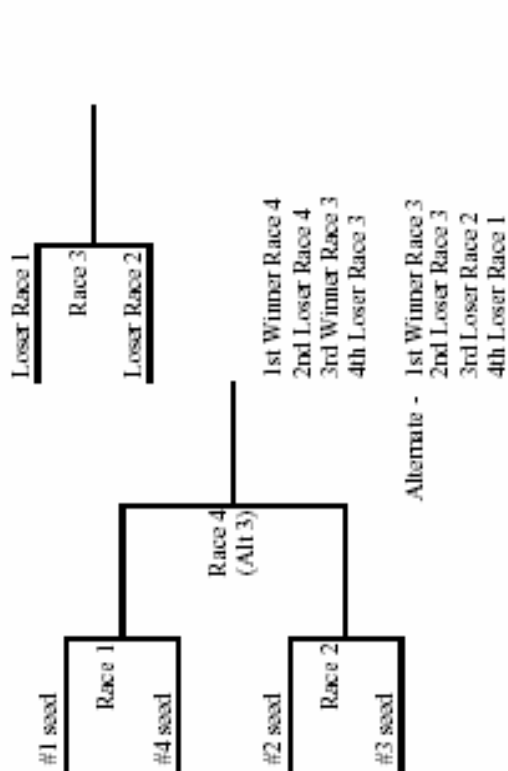

#### 6 Team Single Elimination

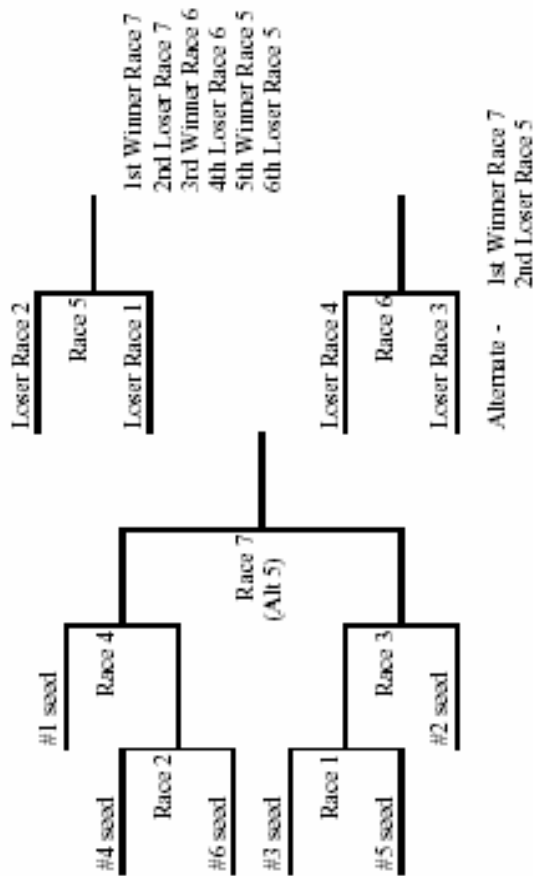

#### 5 Team Single Elimination

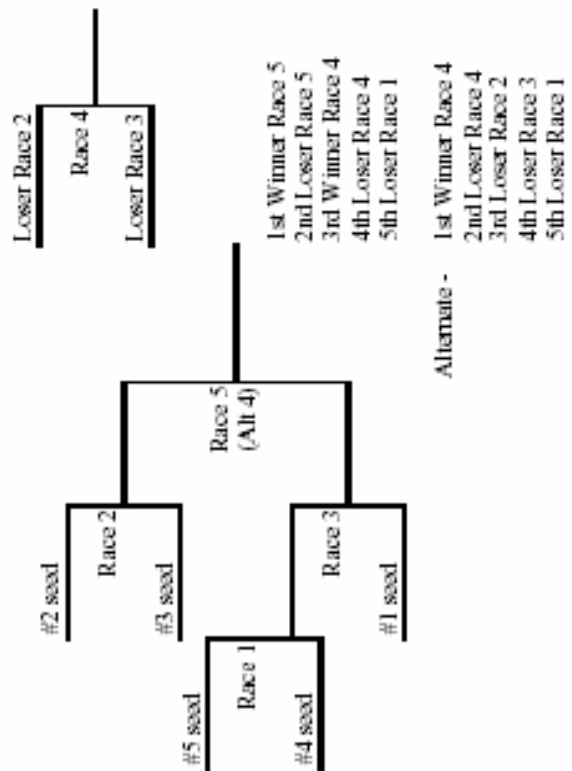

#### 7 Team Single Elimination

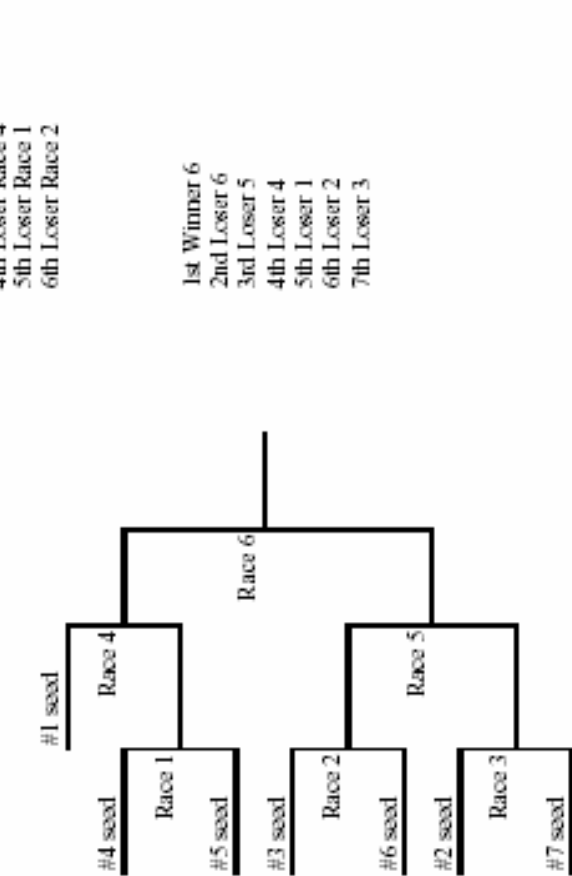

### 8 Team Single Elimination

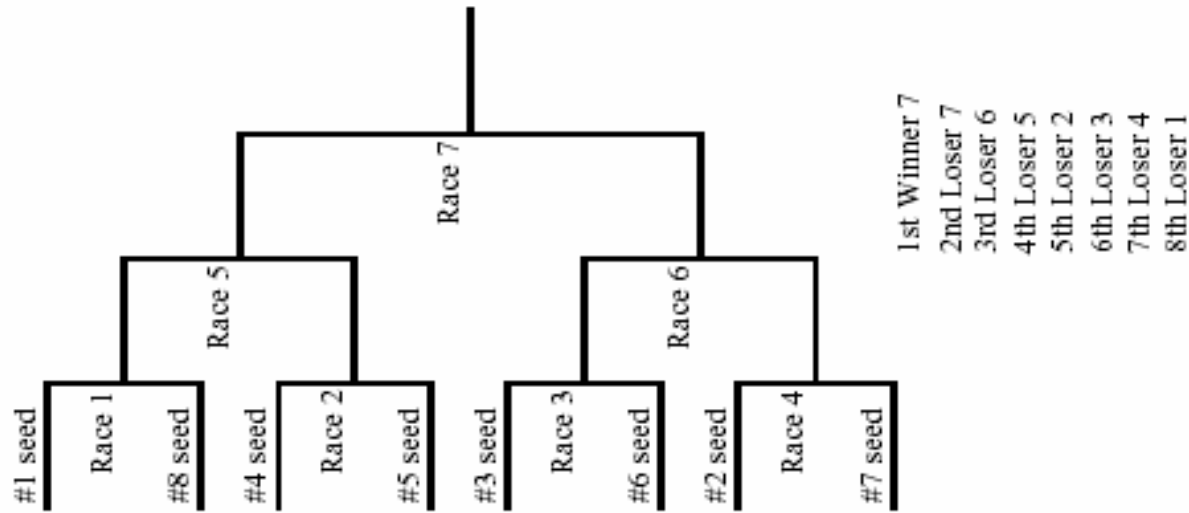

### 9 Team Single Elimination

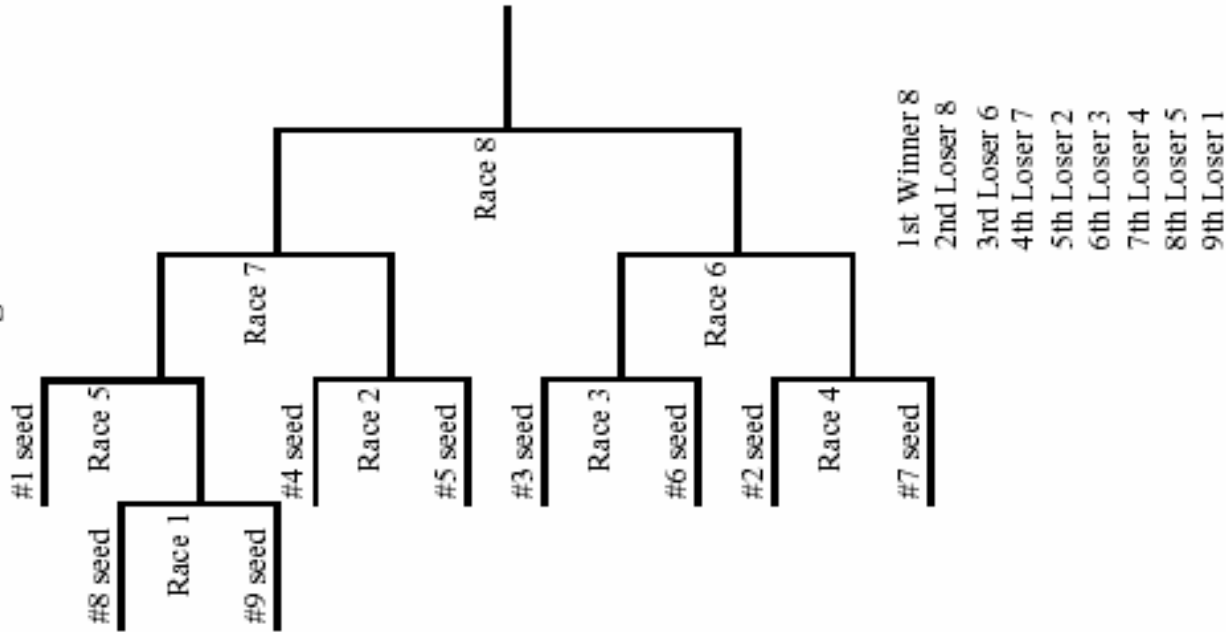

### 10 Team Single Elimination

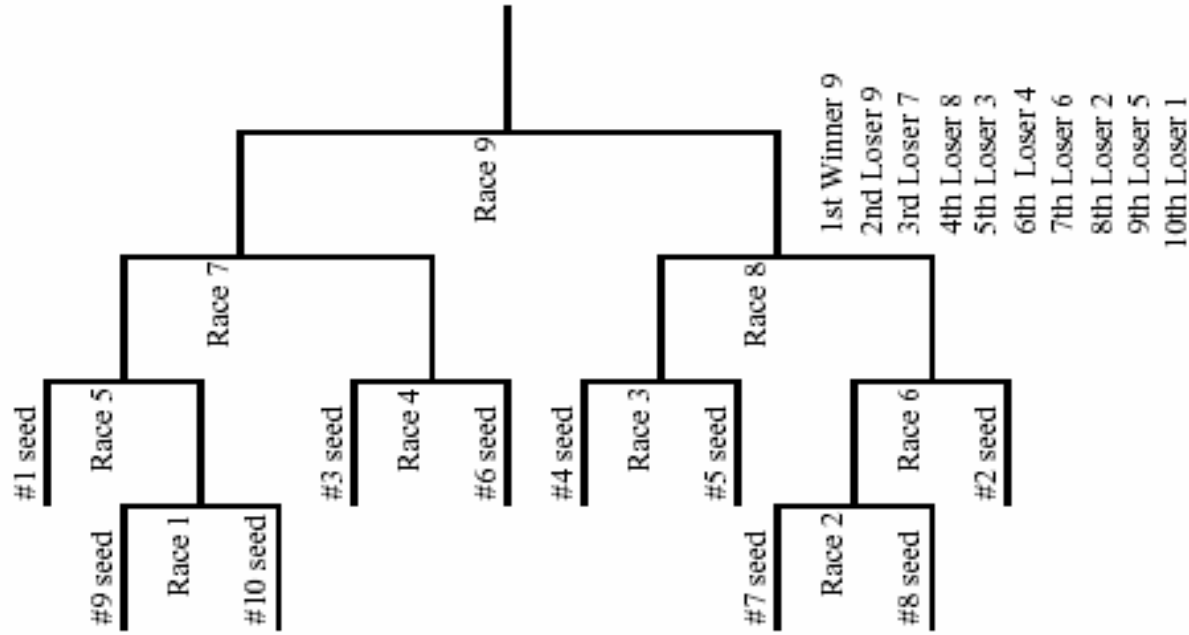

### Section E.1 - Provisional Judges Training

#### ANKC Rules - Chapter 10 – Judges

- (a) Persons interested in becoming an approved ANKC Judge must complete successfully the Provisional Judges Training Program.
- (b) The minimum age for Judges, Stewards and Timekeepers is 18 years of age.

#### Criteria to be met before an application will be considered by the Controlling Body:

- Applicant must be 18 years or over.
- Applicant must be a full financial member of the Controlling Body for a minimum of 2 years.
- Applicant must have been involved in Flyball for a minimum of 2 years.
- Application must be made to the Controlling Body in writing as per the above criteria.
- Provisional Judges Training must be completed within a 12 months period after passing the written Judges exam.

#### STEP 1 - Judges Written Exam:

Before any provisional training can begin the aspiring Judge must complete the Judges exam and pass. The exam is designed to cover as many aspects of the ANKC Flyball Rules.

All written exam papers shall consist of short answer questions and/or multi choice questions only.

- (1) Should an aspirant request an oral exam, the questions shall remain the same, but will be read to the aspirant by an approved independent person.
- (2) The aspirant may write the answers or dictate the answers to the reader, who will then record the answers as dictated. Oral papers will be marked as for written papers.
- (3) There shall be two independent persons appointed to mark the papers. For multi choice questions one person only is required to mark the papers.
- (4) All written exams shall require an 80% pass mark.

**Only after completion and passing of the Judges written exam are Provisional Judges allowed to proceed to Step 2. Notification of approval to proceed will be sent in writing by the Controlling Body.**

#### STEP 2 - Practical Examination:

The ANKC Supervisory Judge will be appointed to supervise your provisional training by the Controlling Body. This Judge will have completed the provisional training themselves, with a sound knowledge of judging and Flyball and have judged at a minimum of twenty (20) competitions.

#### Stewarding to be done by each Provisional Judge:

Inbound Steward for a minimum of twenty (20) races. You are required to fill out the official form provided. The official form must be signed off by the ANKC Judge supervising your training at that competition and the Controlling Body Representative on the day. The ANKC Supervisory Judge will be in the ring next to you for questions and guidance at all times. All forms must be given to the Controlling Body Representative at the end of the competition, to be forwarded to the Controlling Body.

Box Steward for a minimum of twenty (20) races. You are required to fill out the official form provided. The official form must be signed off by the ANKC Judge supervising your training at that competition and the Controlling Body Representative on the day. The ANKC Supervisory Judge will be in the ring next to you for questions and guidance at all times. All forms must be given to the Controlling Body Representative at the end of the competition, to be forwarded to the Controlling Body.

Line Steward for a minimum of twenty (20) races. You are required to fill out the official form provided. The official form must be signed off by the ANKC Judge supervising your training at that competition and the Controlling Body Representative on the day. The ANKC Supervisory Judge will be in the ring next to you for questions and guidance at all times. All forms must be given to the Controlling Body Representative at the end of the competition, to be forwarded to the Controlling Body.

Time keep for a minimum of thirty (30) races to learn the correct procedure for the timing system. They must sit on the timing table with an experienced ANKC Supervisory Judge and learn how to track heat numbers etc and understand the time keeping and how the timing system works. The ANKC Supervisory Judge will be next to you for questions and guidance at all times. You are required to fill out the official form provided. The official form must be signed off by the ANKC Supervisory Judge and the Controlling Body Representative on the day. All forms must be given to the Controlling Body Representative at the end of the competition, to be forwarded to the Controlling Body.

**Assisting in the ring set up: (this may be done at every provisional competition)**

You must assist in the set up of the ring and learn how to square off the box end to be able to lay the two lanes out in a uniform manner. You must assist with putting the timing system together and pulling it apart correctly without ripping out the cords or causing any other possible damage. The timing system is a very delicate and important piece of equipment in Flyball today so the correct use of this equipment is important. This includes unpacking and repacking the timing system in its container. The ANKC Supervisory Judge will be supervising you and assisting you at all times. You are required to fill out the official form provided. The official form must be signed off by the ANKC Supervisory Judge and the Controlling Body Representative on the day. All forms must be given to the Controlling Body Representative at the end of the competition, to be forwarded to the Controlling Body.

**Assisting with measuring of dogs: (this may be done at every provisional competition)**

All Judges should be supervised when measuring dogs' heights. No height card application forms can be sign by a Provisional Judge. The ANKC Supervisory Judge may sign off on the height if the dog has stood quietly by itself with out being held up by the handler and has stood in the correct stance as per the ANKC Rules.

A Provisional Judge should be shown the correct process for measuring a dog's height. They should also learn the correct stance for a dog who is about to be measured. The ANKC Supervisory Judge will be next to you for questions and guidance at all times.

You are required to fill out the official form provided. The official form must be signed off by the ANKC Supervisory Judge and the Controlling Body Representative on the day. All forms must be given to the Controlling Body Representative at the end of the competition, to be forwarded to the Controlling Body.

**Flyball Boxes and Balls: (this may be done at every provisional competition)**

You must learn how to correctly measure the boxes to see if they conform to ANKC Rules. They should be shown how to check balls to see if they comply with ANKC Rules (e.g. balls must bounce like a tennis ball). The ANKC Supervisory Judge will be instructing you and offer assistance if there are any questions and guidance at all times.

You are required to fill out the official form provided. The official form must be signed off by the ANKC Supervisory Judge and the Controlling Body Representative on the day. All forms must be given to the Controlling Body Representative at the end of the competition, to be forwarded to the Controlling Body.

**Only after completion of all the above items in Step 2 are Provisional Judges allowed to proceed to Step 3. Notification of approval to proceed will be sent in writing by the Controlling Body.**

**STEP 3 - Judging in the ring at non sanctioned competitions/demonstrations only where no points are awarded:**

Before a Provisional Judge enters the ring they will be informed by the ANKC Supervisory Judge how to handle any difficult situations when questioned by competitors on rulings. A Provisional Judge will not be judging in a low division or a division one race. They will be judging in a division two race to start with where mistakes are still made by the teams but not in every race.

An ANKC Supervisory Judge of good standing who has completed the provisional training themselves and judged at a minimum of 30 competitions will be appointed to stand beside them in the ring. You will be shown the correct process of checking the stewards and timekeepers are ready and how to start the race. The ANKC Supervisory Judge will stand beside/behind the Provisional Judge in the ring for a minimum of ten races or for their first competition. Then if you are still not sure of yourself the ANKC Supervisory Judge may continue to stand in the ring. The ANKC Supervisory Judge will then move to the back of the ring to watch for any problems that may arise. They will not leave the ring until the Provisional Judge has completed their Judging in the ring.

You are required to fill out the official form provided. The official form must be signed off by the ANKC Supervisory Judge and the Controlling Body Representative on the day. All forms must be given to the Controlling Body Representative at the end of the competition, to be forwarded to the Controlling Body.

To complete the required minimum of competitions a Provisional Judge will Judge at least 10 races at a minimum of 3 competitions during their provisional assignments. Totalling a minimum of 30 races before you can apply to be an approved ANKC Judge.

The ANKC Supervisory Judge will be at the back ring (or next to you) for questions and guidance at all times.

When you have submitted your application form you will be required by the Controlling Body to do a practical review under the ANKC Supervisory Judge at a sanctioned competition. The ANKC Supervisory Judge will then submit a written report to the Controlling Body.